

WURLITZER CONSOLES

By Judd Walton

There have been numerous comments within these pages on the correct terminology used to describe the stop tablet assembly horseshoe mounted in theater organ consoles -- "bolster" or "stop rail". It has recently been stated in print that the term bolster is incorrect and that stop rail is the term that should be used. As a result of this confusion it seemed advisable to conduct a little research to determine once and for all why the term bolster was considered incorrect. This has resulted in a set of blueprints supplied through the kind permission of Mr. Farny Wurlitzer which illustrate various Wurlitzer console models. These are reproduced as part of this article and you will note that the term bolster is used as well as the terms "single" or "double deck" bolster. In checking the large library version of the Webster dictionary, it was found that "bolster" is defined "to lay alongside", which perfectly describes the stop tablet arrangement. It, therefore, becomes obvious that the term "bolster" is correct and should continue to be used.

The prints also clear up some other matters regarding terminology used to describe the various consoles. What has been referred to as a "waterfall" console is in reality known as a French console. The applique designs, if any, do not change the terminology. The terms Modernistic and Chinese as seen

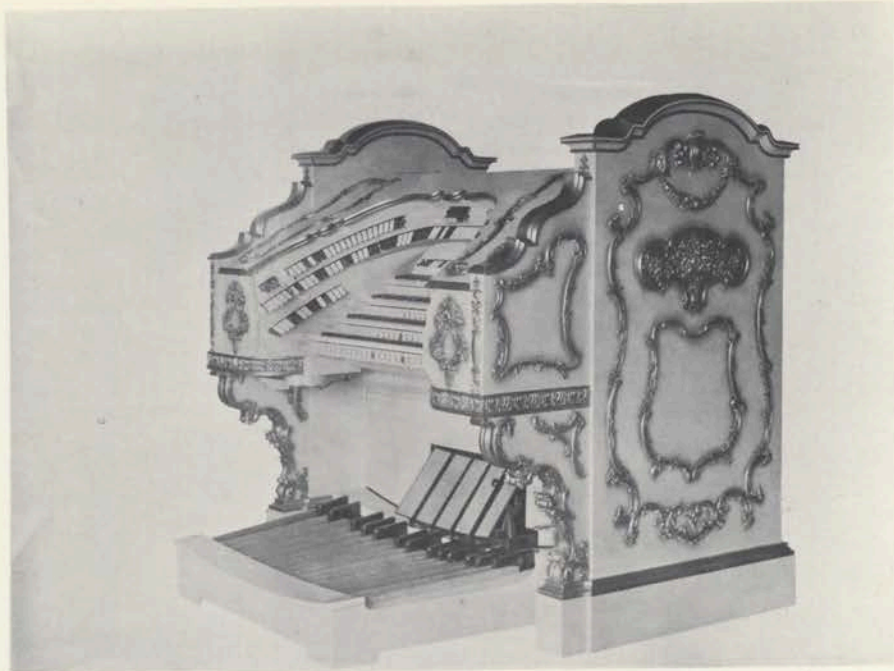

French console with roccoco brackets, flower basket design applique, style 270, Opus No. 1819, Paramount Theatre, Seattle, Washington.

on the prints are self-explanatory. Has anyone ever seen the Chinese console pictured?

There were several variations of the French console which the accompanying pictures show. There was also the Roman console, of which at least two examples are known -- the former Minnesota Theater Wurlitzer from Minneapolis, Opus No. 1848, now in Reiny Delzer's home, and the Toledo, Ohio, Paramount Theater. The columns in the front with the Acanthaa leaf capitals on the columns, as well as the decorative tops, are unmistakably Roman. The Wurlitzer installed in the Paramount Theatre in Port-

land, Oregon, Opus No. 1831, is described as "Grecian," undoubtedly due to the Grecian design of the applique and the "urns" adorning the top of the console. There were several other stylized versions of the French console which are pictured below. The Paramount Theatre Wurlitzer console, Seattle Washington has a French console with an applique flower basket design. An Arabic design is evident in the three manual console version as pictured, with its spiral columns. Some of the French consoles were almost plain as in the version delivered to the Regent Theatre in Sydney, Australia as the picture illustrates. Apparently the theatre interior design had considerable influence on the console design. Radio City Music Hall's organs had a very modern console design seen nowhere else, even to the straight bolster organ installed in the Rainbow room.

The Straight bolster styles, usually delivered to churches and homes, also came in several console designs. The Gothic design usually prevailed in churches, but there was also a scroll model as seen in the organ installed in Tokyo (another is presently located in the Long Beach, California, auditorium).

Suffice it to say, the design of the Wurlitzer consoles was excellent. The proportions were well carried out, graceful, and pleasing to the eye. They have a good feel to the organist and except for a few dimensions, notably the length of the pedal keys, they meet A.G.O. specifications almost entirely.

The first Wurlitzer consoles had panelled sides and backs. They were

(Continued On Page 25)

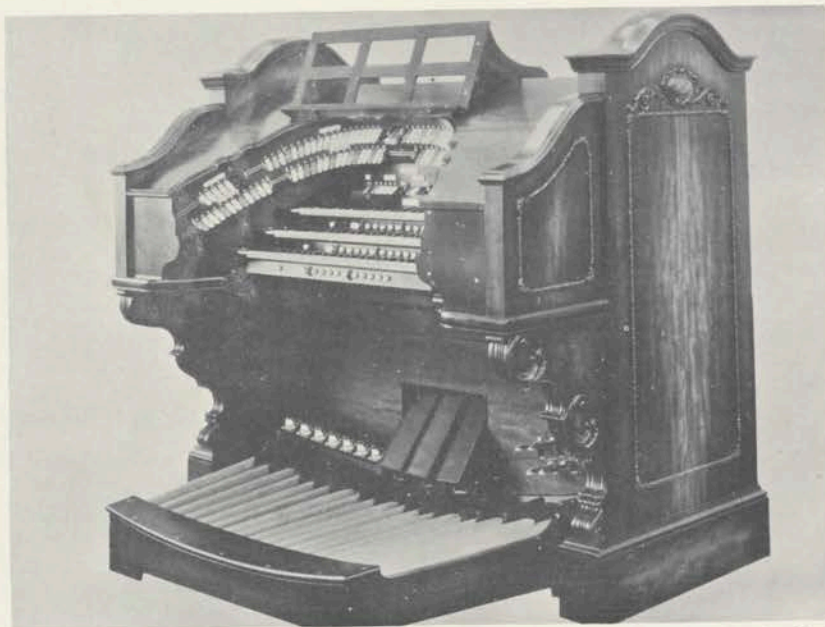

French console, first used at Shea's Bailey Avenue Theatre, Buffalo, New York, Opus No. 1950.



meet the Celebrity— new **Thomas** all-transistor organ with the fabulous Band Box at no extra cost

Like its looks? You'll also like the magnificent sound of this new Thomas all-transistor organ with the Band Box that adds 10 percussion instruments including cymbals, bongoes, castanets, claves and drums. Meet the "Celebrity" at your local Thomas organ dealer's—soon.

"Celebrity" offers you:

- Two 61-note keyboards
- 8 thumb pistons
- Band Box
- 30 voices
- keyboard sustain
- pedal sustain
- 25-note detachable pedalboard
- 2-speed Leslie speaker
- Color-Tone percussion
- Vibra Magic
- all-transistor 150-watt peak power stereo amplifier

Every Thomas Organ comes with a 5-year warranty on tone generator boards—heart of the Thomas.

Thomas Organ Co., Dept. 113, 8345 Hayvenhurst Ave., Sepulveda, California. Subsidiary of Warwick Electronics, Inc.

WURLITZER CONSOLE

(Continued From Page 21)

not referred to by any name until a later model was introduced in 1927-28 which was called the "Scroll" console. The term applying to the scroll design of the bracket or corbel under the key shelf as well as the curved design of the horseshoe-shaped top board. The first models then became known as "Panelled" consoles; very early models had a closed bracket with a shell-like design under the key shelf, which was later followed by the "open" bracket models which were produced up to the time of the introduction of the "Scroll" console.

The "Panel" console was used on some organs for nearly a year after the "Scroll" model was introduced to use up console shells already produced and in stock, notably three-manual, single-bolster models; the "Scroll" console later appeared for this model. In order to complete the information on consoles, field measurements were taken of two-, three-, and four-manual "Panel" and "Scroll" consoles. Basically, the dimensions for all two-manual and three-manual consoles are the same, as the following information demonstrates. In the later model consoles Wurlitzer built two four-manual shells, a standard four-manual shell and an enlarged four-manual shell designated as a "special 4 manual". The larger console shell was used for the four-manual, 36-rank

Wurlitzers as well as a few of the other large models. This same console shell was also used for the three five-manual organs. The five manuals were made to fit by making the top three manuals with shorter keys and using short stop tablets on the straight bolster over the top manual. In other words, there were no special console shells made to accommodate the five manuals,

apparently, which is understandable when one realizes the production costs involved in any special design.

Panel consoles have a Brass nameplate, one of which was mounted on each side of the console. Fortunate indeed is the enthusiast who acquires a Wurlitzer and finds the nameplates still in place

(Continued On Page 26)



An early two manual paneled console with closed bracket, probably Opus No. 360 or No. 362, Blue Mouse Theatre, Seattle, Washington. Note divided side panels which were later changed to a single side panel.

WURLITZER

(Continued From Page 25)

as they were more often than not long ago stolen as souvenirs. They are being reproduced, however, in the San Francisco area, and anyone wanting such will be given the name of the person to contact by dropping a note to this magazine. The scroll consoles have an inlaid nameplate of wood and brass. These are more often found intact as they were glued in place. They are very highly prized, having beautifully done wood inlay design using various wood and burl as well as a brass inlaid violin. It is not known if they are being reproduced, but if so, we would like to be advised.

Perhaps the most interesting console dimension is that which determines the minimum space required to pass a console through an opening, and the following applies. For two-manual consoles a minimum of 36 inches is required; a three-manual console requires 45 inches; a standard shell four-manual console requires 51 inches; and the special four-manual console shell requires a minimum of 52 inches. Incidentally, normal home construction allows for a floor live load of 75 pounds per square foot which is ample to support any Wurlitzer consoles.

We are indebted to Mr. Farny Wurlitzer for supplying us with the original prints and to the following who supplied us with information to complete the article -- Dick Loderhose, Frank and Lloyd Lanterman, Gordon Kibbee, John Leininger, Stu Green, and Bob Jacobus.



French console with Arabic design, Opus number unknown, style 235 (factory print).

All Photos
And Diagrams
In This Article
Are From The
JUDD WALTON
COLLECTION



Roman console, Style 270, Opus No. 1848, Minnesota Theatre, Minneapolis, Minnesota, now in Reiny Delzer's home, Bismark, North Dakota.



Modernistic console Opus No. 2164, Paramount Theatre, Oakland, California, made in both 3 and 4 manual styles.



Straight Bolster, Style R16 console, Opus No. 2185, Rainbow Ballroom, Radio City, New York, New York, now in Joe Oelhaf residence, New York.

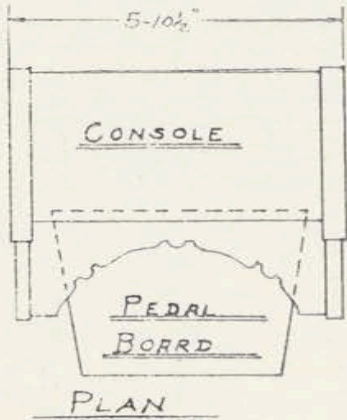

4 MANUAL MODERNISTIC DESIGN CONSOLE

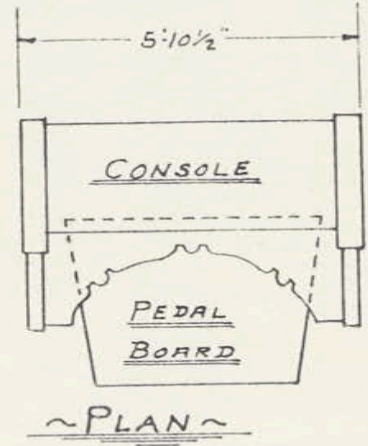
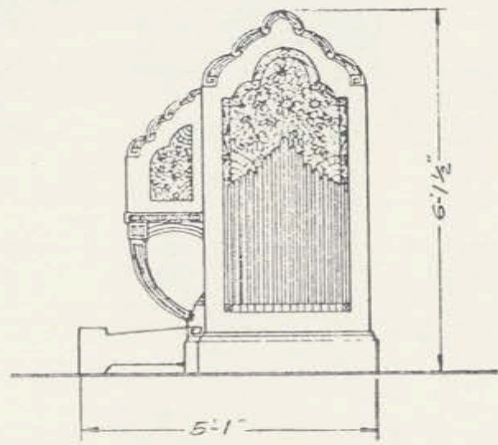

3 MANUAL CHINESE DESIGN CONSOLE

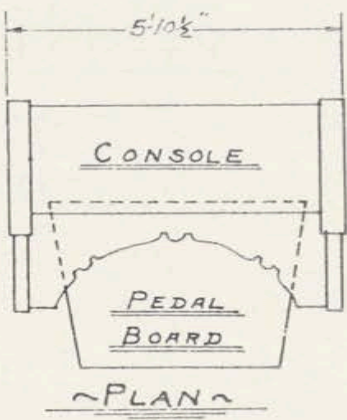
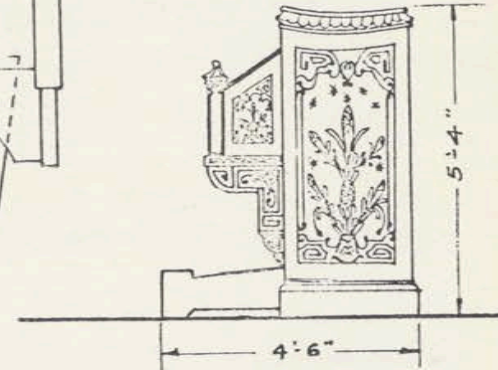

3 MANUAL MODERNISTIC DESIGN CONSOLE

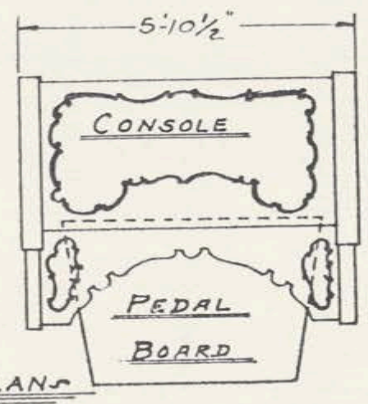
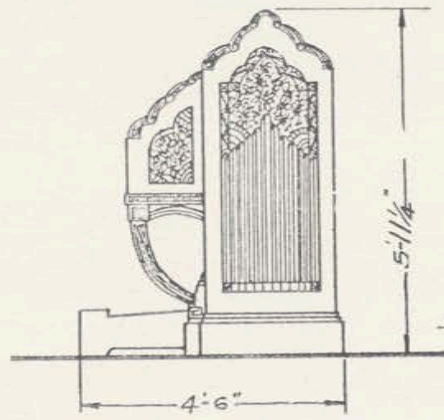

4 MANUAL FRENCH DESIGN CONSOLE

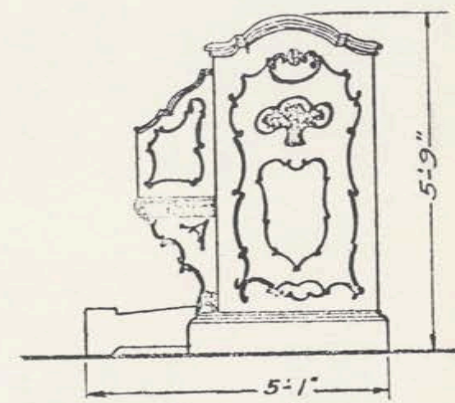

THE RUDOLPH WURLITZER MFG. CO.,		N. TONAWANDA, N. Y.	
REVISIONS	NAME <u>SPECIAL DESIGN CONSOLES</u>		
	FOR <u>PARAMOUNT THEATER</u>		
	DATE <u>10-30-'30</u>	CHECKED	
	DRAWN <u>ROGGE</u>	APPROVED	

2-MANUAL SINGLE BOLSTER
APPROX. WGT. 700 LBS.

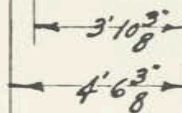
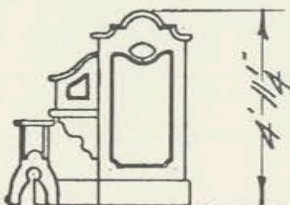
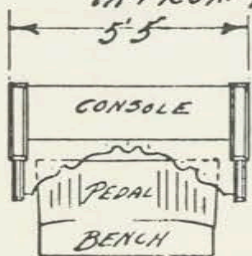

NOTE
ELEVATOR LIFT PLAT-
FORM TO EXTEND
6" FROM CONSOLE
ON ALL SIDES

3-MANUAL DOUBLE BOLSTER
APPROX. WGT. 900 LBS.

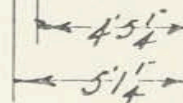
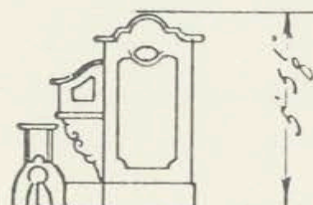
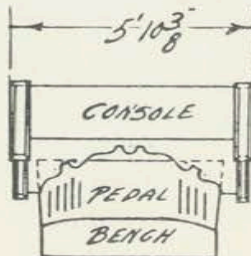

2-MANUAL DOUBLE BOLSTER
APPROX. WGT. 700 LBS.

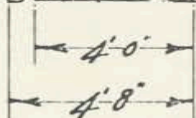
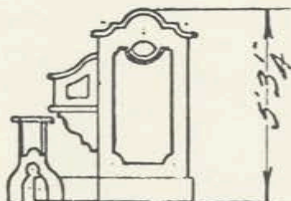
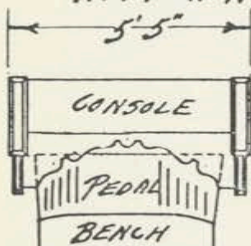

3-MANUAL SINGLE BOLSTER
APPROX. WGT. 900 LBS.

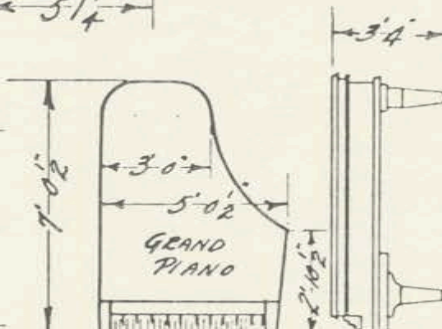
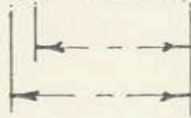
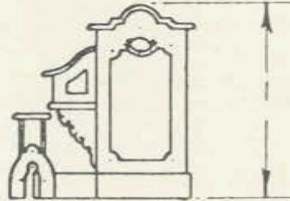
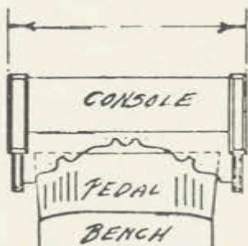

2-MANUAL CHURCH STYLE
STRAIGHT CONSOLE

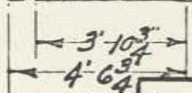
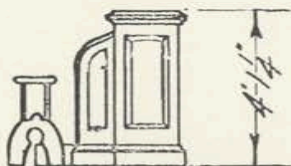
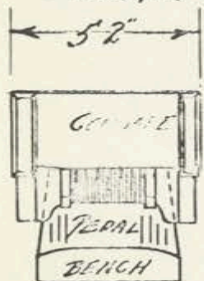

2-MANUAL CHURCH STYLE
CURVE CONSOLE

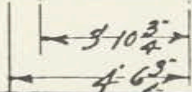
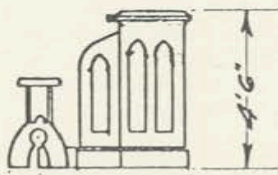
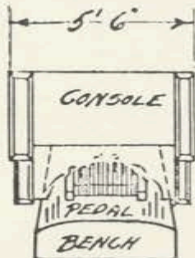

4-MANUAL DOUBLE BOLSTER
APPROX. WGT. 1600 LBS.

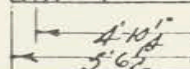
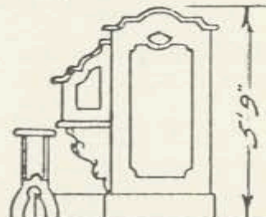
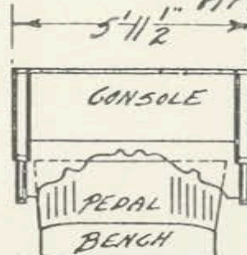

Ch'g'd	From	Date	Ordered by	THE RUDOLPH WURLITZER MFG. CO. N. TONAWANDA, N. Y.			
				Scale 1/4"=1'	Part No.	Name CONSOLE DIMENSIONS	
				Date 10-30-28	File	Mach.	
				- REQ'D.	Patt. No.	Size	Mat.
				Drawn J.A.L.	Traced	Checked	Approved

3-17-46

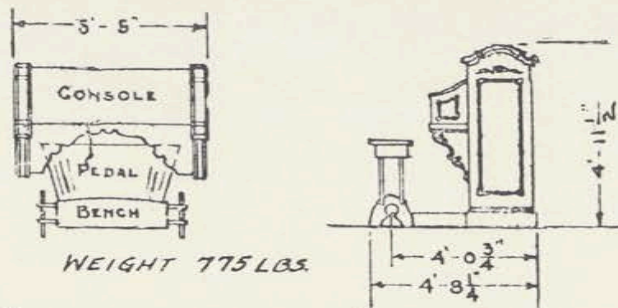

WEIGHT 775 LBS.

STANDARD 2 MANUAL SINGLE DECK CURVED BOLSTER CONSOLE

- STYLE 115
 " 120
 " 125
 " 130
 " 140
 " 150
 " 160
 " 175
 " 190

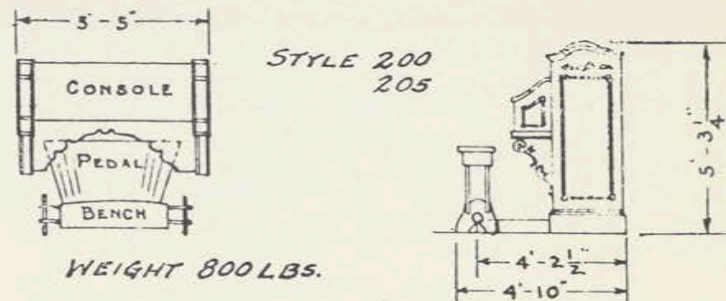

WEIGHT 800 LBS.

STANDARD 2 MANUAL DOUBLE DECK CURVED BOLSTER CONSOLE

- STYLE 200
 205

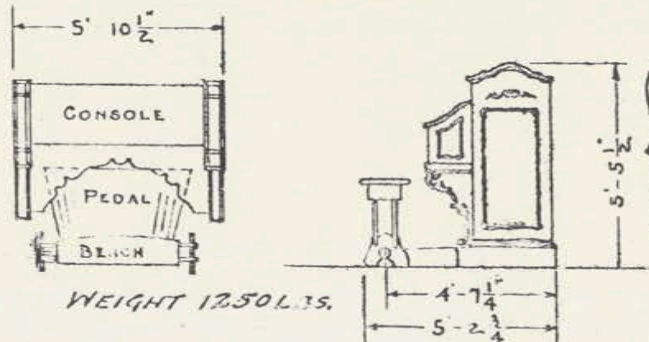

WEIGHT 1250 LBS.

STANDARD 3 MANUAL DOUBLE DECK CURVED BOLSTER CONSOLE

- STYLE 220
 " 225
 " 230
 " 240
 " 250
 " 260

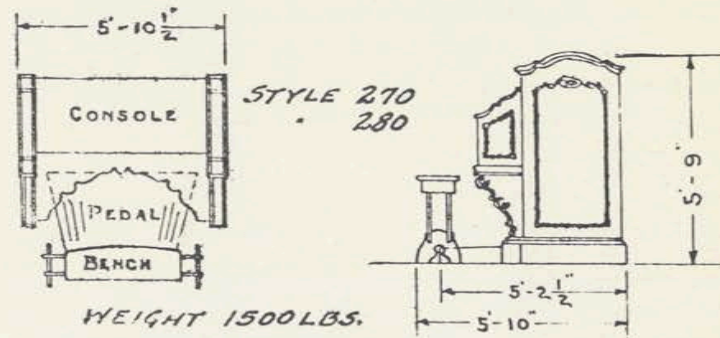

WEIGHT 1500 LBS.

STANDARD 4 MANUAL DOUBLE DECK CURVED BOLSTER CONSOLE

- STYLE 270
 280

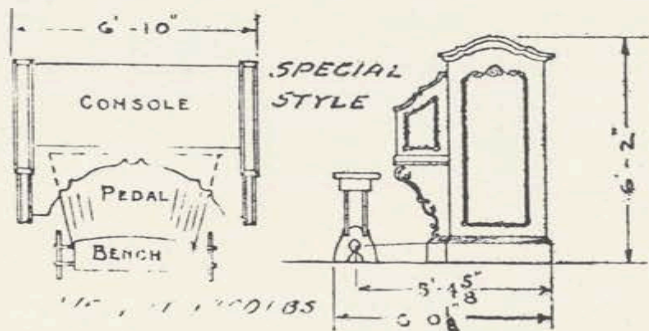

WEIGHT 1400 LBS.

STANDARD 2 MANUAL CURVED BOLSTER CONSOLE

SPECIAL STYLE

Eng'd	From	Date	Ordered by	THE RUDOLPH WURLITZER MFG. CO. N. TONAWANDA, N. Y.			
				Scale $\frac{1}{4} = 1'-0"$	Part No.	Name CONSOLE DIMENSIONS	
				Date 3-21-29	File	Mach. THEATRE CONSOLES	
				REQ'D.	Pat. No.	Size	Mat.
				Drawn E. D. BORS	Traced	Checked	Approved

3-3474

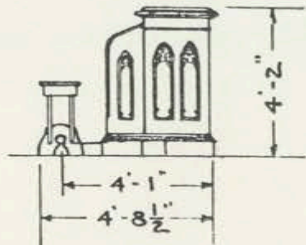
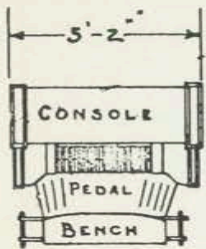

2 MANUAL - STRAIGHT BOLSTER - CHURCH
GOTHIC DESIGN - APPROX. WGT. LBS.

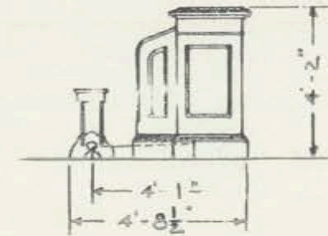
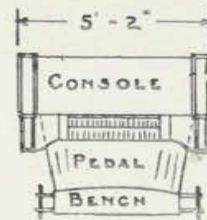

2 MANUAL - CHURCH CONSOLE - STRAIGHT
BOLSTER - APPROX. WGT. LBS.

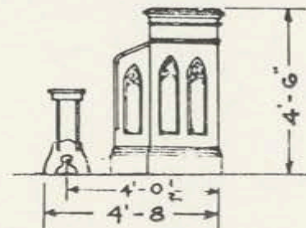
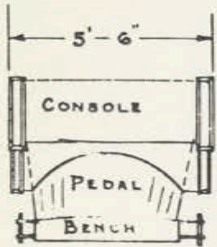

2 MANUAL GOTHIC CHURCH CONSOLE
CURVED BOLSTER - APPROX. LBS.

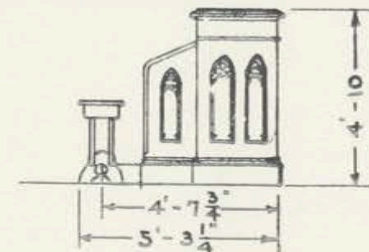
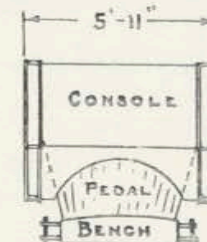

3 MANUAL GOTHIC CHURCH CONSOLE
SINGLE CURVED BOLSTER - APPROX. LBS.

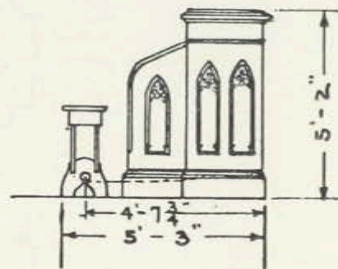
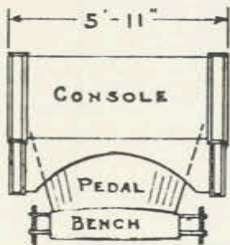

3 MANUAL GOTHIC CHURCH CONSOLE
DOUBLE CURVED BOLSTER APPROX. LBS.

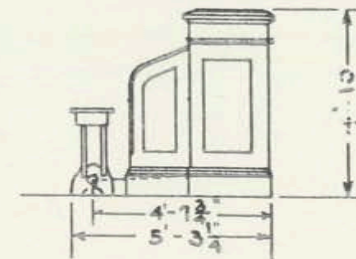
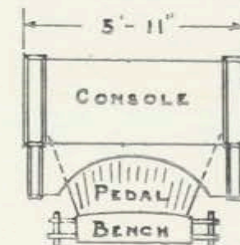

3 MANUAL CHURCH CONSOLE - SINGLE
CURVED BOLSTER - APPROX. WGT. LBS.
(DOUBLE BOLSTER DIMENSIONS SAME AS 3 MAN. GOTHIC)

Qty	From	Date	Ordered by	THE RUDOLPH WHEATZLER MFG. CO. N. TONAWANDA N. Y.			
				Scale $\frac{1}{4}'' = 1'-0''$	File No.	Name CONSOLE DIMENSIONS FOR	
				Date 3-19-29	File	Mach. CHURCH CONSOLES	
				- REQ'D.	Pat. No.	Size	Mat.
				Drawn E. D. DORS	Traced	Checked	Approved 3-34-

SCROLL CONSOLE DIMENSIONS
(from measurements in the field)

2 Manual Single Bolster

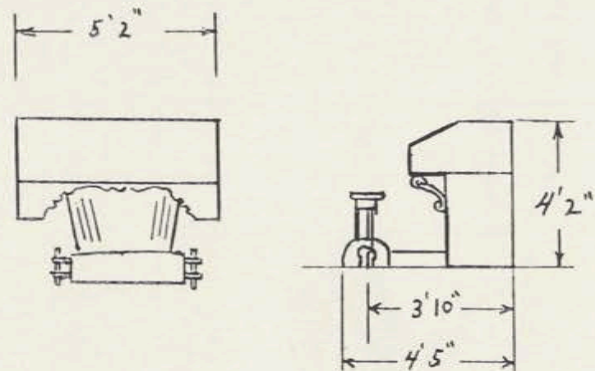

4 Manual Special Double Bolster

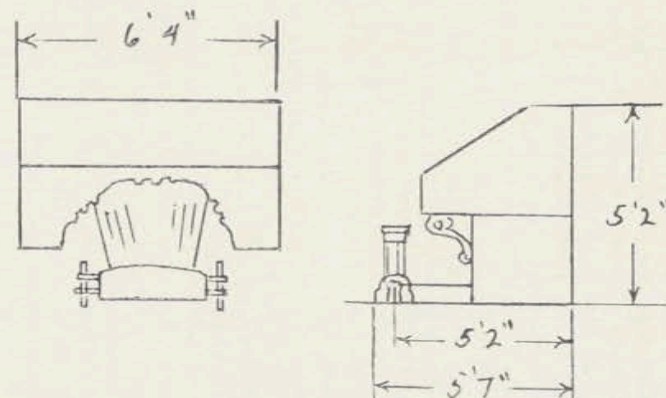

3 Manual Double Bolster

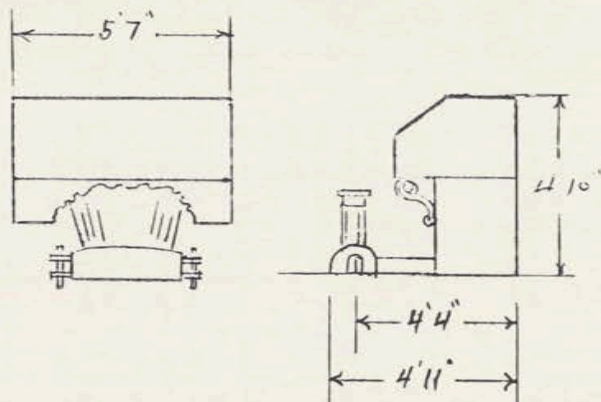

4 Manual Double Bolster

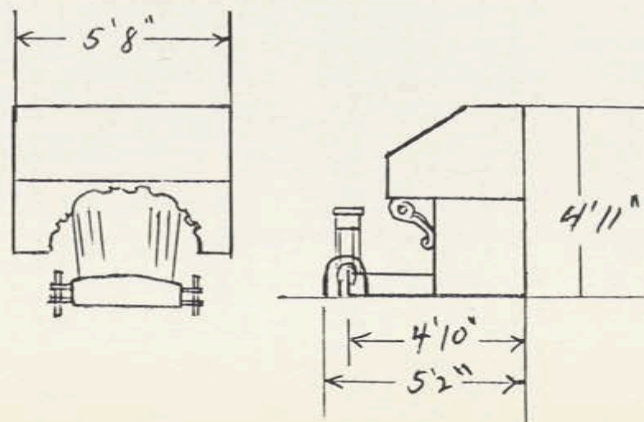

All measurements plus or minus 1/4\".

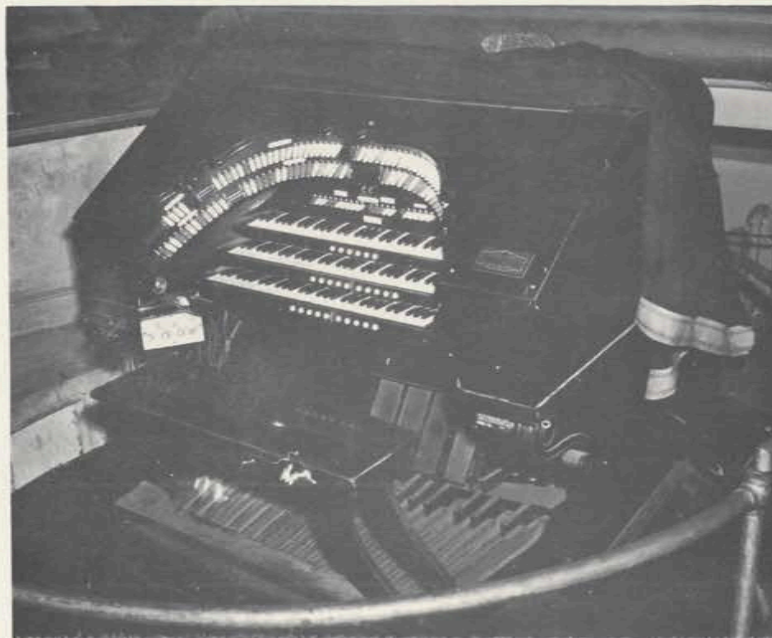

Scroll console, Style 235 special, Opus No. 1890,
Fox Oakland Theatre, Oakland, California now
owned by John Leininger, Redding, California.