

THEATRE ORGAN

January / February 1986

ISSN 0040-5531



Two Great Names in the Theatre Organ World

With your help, the legend and the organ will go on forever!



JESSE CRAWFORD

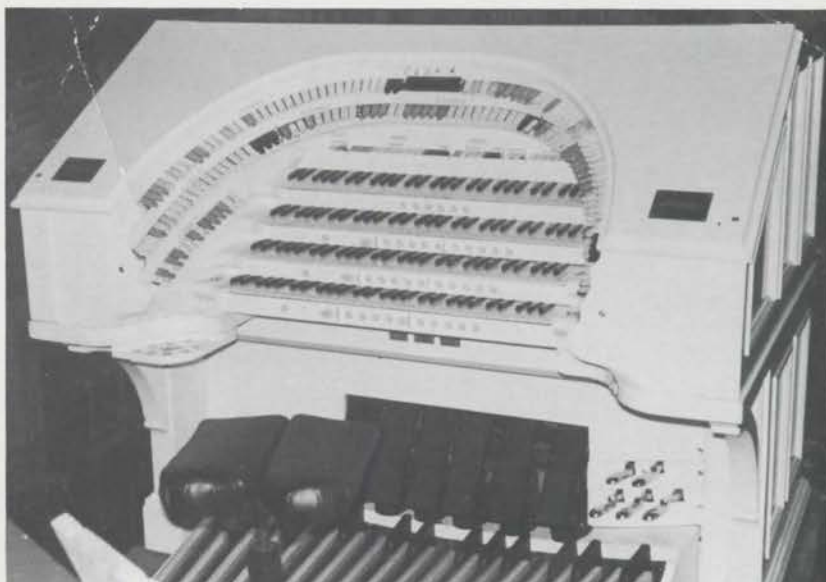

CHICAGO THEATRE WURLITZER CONSOLE

Since 1977 CATOE, with the help of the American Theatre Organ Society has been working to save one of the most famous theatre pipe organs -

THE CHICAGO THEATRE

At last we can truly say the Chicago Theatre is secure. The building is now owned by a group of people who understand its historical significance as well as the need for preserving all of its entertainment capabilities. CATOE and ATOS have played a major role in the success of the campaign.

It is no secret that the Chicago Theatre Wurlitzer is in need of a complete and thorough restoration. Now that the future of the theatre is secured, that work can begin. As a first step CATOE has made a firm agreement with the new owner of the Chicago to insure that the Wurlitzer will play a role in that future of the building and that CATOE will oversee the restoration and the maintenance of the instrument.

At the present time CATOE is undertaking the restoration and re-installation of the 4/20 Oriental Wurlitzer, the care and location of the well known Indiana Theatre Wurlitzer, in addition to the ongoing maintenance and operation of many other Bartons, Kimballs, Genevas and Smiths in the Chicago area. The challenges are sometimes staggering but we are committed to keep theatre organ alive and well in Chicago for everyone to enjoy.

Frankly speaking, CATOE needs your help! We want to do the Chicago Theatre Wurlitzer restoration absolutely as complete and perfectly as is possible. Your contributions of funds to help raise the thousands of dollars necessary can help secure, for you and for ATOS, a place and an instrument of unparalleled historical and musical importance. We feel confident that our "taking care of our own" in the course of the Chicago Theatre restoration will insure that ATOS will always be welcomed there to enjoy this magnificent instrument.

Contributions to CATOE for the Chicago Theatre Wurlitzer restoration fund are totally tax deductible and *all* of the funds you designate for that project will be spent entirely on the Chicago Theatre Wurlitzer. A careful record will be kept of all those who participate in this project whether your contribution be one or one thousand dollars.

Please send your tax free donation to:
C.A.T.O.E., Chicago Theatre Wurlitzer Fund
103 E. Chestnut
Chicago, Illinois 60611

With your help the Chicago Theatre Wurlitzer will truly take its place as the centerpiece of the next ATOS convention in Chicago.

THEATRE ORGAN

(ISSN 0040-5531)

JOURNAL OF THE
AMERICAN
THEATRE ORGAN
SOCIETY

Library of Congress
Catalog Number — ML1 T 334

VOLUME 28, NUMBER 1
JANUARY/FEBRUARY 1986

Editorial

Robert M. Gilbert
3448 Cowper Court
Palo Alto, California 94306
Phone: 415/494-1870

Advertising

Len Clarke
1839 Weeg Way
Park Ridge, Illinois 60068
Phone: 312/692-9399

Back Issues & Binders

Vernon P. Bickel
1393 Don Carlos Court
Chula Vista, California 92010
Phone: 619/421-9629

President

Jack Moelmann
P.O. Box 13106
Omaha, Nebraska 68113
Phone: 402/292-7799

Vice President

Russell Joseph
18 Fenchurch Drive
Bella Vista, Arkansas 72714
Phone: 501/855-1002

Secretary

David M. Barnett
423 North Stafford Avenue
Richmond, Virginia 23220
Phone: 804/359-6318

Treasurer

Warren D. "Dale" Mendenhall
4428 Pennsylvania Avenue
Fair Oaks, California 95628
Phone: 916/967-5060

Executive Director

Douglas C. Fisk
P.O. Box 420490
Sacramento, California 95842
Phone: 916/962-1019

Board of Directors

Lowell C. Ayars
Tom B'hend
Dr. John W. Landon
Allen R. Miller
Ashley Miller
Fr. James Miller
Lois F. Segur
Richard J. Sklenar
Walter Strony
Rex Koury, Past President

Corporate Office

American Theatre Organ Society, Inc.
1393 Don Carlos Court
Chula Vista, California 92010

Curator — Archive/Library

Vernon P. Bickel
1393 Don Carlos Court
Chula Vista, California 92010
Phone: 619/421-9629

Journal Staff

Editor — Robert M. Gilbert
Co-editor — Grace E. McGinnis
Editor Emeritus — W. Stu Green
Associate Editors
Lloyd E. Klos
Peg Nielsen
Verna Mae Wilson
Photographer —
Art Director — Floyd A. Mumm
Advertising — Len Clarke
Publisher — Warren Dale Mendenhall

Design & Typesetting

Pica Studio
Livonia, Michigan

Printing & Mailing

Scott Publications
Livonia, Michigan

features . . .

- 5 The Byrd Theatre Miles J. Rudisill, Jr.
8 The Phoenix Festival Was Fantastic Grace E. McGinnis
10 Edward Swan, Theatre Organist Lloyd E. Klos
12 Repairing and Voicing Damaged Organ Pipes Dan Barton
14 Another Opening, Another Show Dr. Larry Warkintin
24 Dan Barton's Tuning Procedure Revisited John L. Little
25 May we introduce . . . Melissa Ambrose Grace E. McGinnis
28 The Theatre Organ . . . Wherein Lies Its Future? . . John Ledwon

departments . . .

- | | |
|---------------------------------|----------------------------|
| 4 Executive Messages | 26 Book Reviews |
| 7 Johnson's Quiz Question | 29 Pipes and Personalities |
| 16 For the Records | 31 Closing Chord |
| 19 Biographical Dictionary | 32 Letters to the Editors |
| 22 Nuggets from the Golden Days | 33 Chapter Notes |
| 26 Keyboard Techniques | 54 Classified Ads |

Cover Photo

Views of the Byrd Theatre in Richmond,
Virginia. See story beginning on page five.

ATOS National Membership is \$20.00 per year, which includes a subscription to THEATRE ORGAN, the official publication of the American Theatre Organ Society. Single copies \$2.50. Make check or money order payable to ATOS, and mail to ATOS Membership Office, P.O. Box 420490, Sacramento, Calif. 95842.

profit organization. Jack Moelmann, President. All rights reserved. Entire contents copyrighted, American Theatre Organ Society, Inc., 1985. Office of publication is 4428 Pennsylvania Avenue, Fair Oaks, California 95628.

THEATRE ORGAN (title registered U.S. Patent Office) is published bimonthly by the American Theatre Organ Society, Inc., a non-

POSTMASTER: Second Class postage paid at Livonia, Michigan. IF UNDELIVERABLE, send form 3579 to ATOS Membership Office, P.O. Box 420490 Sacramento, Calif. 95842.

American Theatre Organ Society

PRESIDENT'S MESSAGE



A big "well done" goes to the Valley of the Sun Chapter for putting on a terrific "Phoenix Festival '85" regional convention in November. For those who attended it was a memorable event. During that convention Walt Strony, the convention chairman, presented a check for \$1000 to ATOS for use in the Young Organist Competition program. A big THANK YOU for this most generous gift.

Speaking of the Young Organist Competition, the information on this year's program

has been sent to all chapter presidents. We look forward to having a lot of participation this year. As you have noticed, we have expanded the competition to include three winners instead of just one. The overall winner, however, will be the one who will be featured in a cameo during the 1986 National Convention in Richmond, Virginia.

After great deliberation, the term "Chapter Chairman" will no longer be used as far as the national board is concerned. The more appropriate title of "President" will be used in referring to chapter leadership. We recognize that there may be local reasons for referring to the chapter officer by another title, but Chapter President, in our opinion, more appropriately reflects the job of the chapter leader.

The 2/5 Wurlitzer organ in the Carnegie Hall Cinema has to be removed. The organ was donated to ATOS some years ago as a memorial to the late Ben Hall (it was Ben's organ and called "Little Mother"). Over the years the organ has provided enjoyment to those who visited the Carnegie Hall Cinema in New York, but plans for the theatre neces-

sitate it being removed. This is the only organ owned by the American Theatre Organ Society, and we want to ensure that it gets a good home. You will be advised of progress on this program.

1986 will be an exciting year. From reading the newsletters from the various chapters, there is a lot going on and a lot more to do. The Young Organist Competition, increased membership, ATOS promotion, the Archives/Library, and an exciting convention in Richmond in July are at the forefront of our activities. Our Promotion and Convention Planning committees are hard at work promoting ATOS to the world and developing procedures and guidelines for exciting conventions in the future. We are also attempting to get a grasp on how conventions should be reviewed; your concerns have been noted.

It is time to consider nominations for the ATOS Board of Directors. We need new people to serve our organization. Being on the board is challenging and fun, and you would be helping a growing organization to achieve its goals. Think about running or nominating someone who would do a good job.

Your officers and Board of Directors wish each of you a happy and prosperous New Year.

Sincerely,

Jack Moelmann

EXECUTIVE DIRECTOR'S MESSAGE



Mail during the past weeks has been heavy with membership renewals for 1986. Along with the renewals came many notes and letters. One idea expressed in a number of different ways is the need for ATOS to consider a restatement of its purpose. The Society was developed to preserve the theatre organ. While that must continue (many are still being lost), their long-term preservation must be tied to how they are used now and in the future. Using them only in the

"recital" form or with silent films and sing-alongs will not attract a sufficient audience of younger people to assure that many will be around 25-50 years from now.

As the theatre organ and the public programs are the life blood of chapters, maybe it is time that more thought be given to different uses

or presentations. The search is for the key to finding a segment of a new generation that will want to use the theatre organ in new and different ways. And maybe the ATOS purpose should be changed from "preservation" to "preservation and presentations" to get more thinking geared to reaching new audiences. Any specific ideas? Send them in and we will find a way of sharing them.

Another point of interest with the renewals is the number of members who voluntarily contribute more than the basic dues. As an expression of appreciation and recognition to those members, the May/June THEATRE ORGAN will carry a list of all who have qualified as Contributors, Sustainers, Patrons or Benefactors. Should you be one who does not wish to be listed please let me know by March 15.

Sincerely,

Douglas C. Fisk



The Byrd Theatre

America's Most Beautiful Neighborhood Movie Palace

by Miles J. Rudisill, Jr.

Even as Richmond's Byrd Theatre swung open its 28 magnificent brass doors to the public on Christmas Eve 1928, the silent films the organ was designed to accompany were fast taking a back seat to the "talkies." This beautiful theatre, however, remains today as a monument to the past and a hope for the future, as it is one of the last surviving movie palaces still in operation as a commercial enterprise. Ten years ago the Byrd was recognized by the Commonwealth of Virginia as being the last of its kind in the state, and it is now a Virginia Historic Landmark and is listed in the National Register of Historic Places. It is recognized as probably America's best-preserved example of a neighborhood movie palace. Designed in the manner of an opera house by architect and contractor Fred Bishop, a native Richmonder, the theatre was decorated by Brounet Studios of New York in a basic color scheme of red and gold in the French Baroque style of the Napoleonic period.

The theatre operated continuously for nearly 55 years, but was closed after its last performance of *Giant* on May 15, 1983. The Neighborhood Theatre chain had operated this jewel of a movie palace for 45 years; however, the changing customs of booking arrangements and movie-going habits, accounting for mounting losses by the chain, caused the final decision. But the magnificent house refused to die, even though its future remained uncertain for a period of months until the owners, Mr. and Mrs. Samuel Warren of Arlington, Virginia, decided to re-open the theatre under independent management.

Duane Nelson, who had managed the theatre for the Neighborhood chain, was appointed General Manager, and it was under his guidance that needed restoration was un-

dertaken. Because most of the original fixtures remained and were in working condition, much of the restoration involved painting and cleaning.

The lobby was painted, sponged to be exact, and was done over three times before the desired effect was achieved. Rag painting was too coarse in texture, so paint was applied by hand, using a sponge dipped in the paint. Three colors were blended by sponge to give the look that was so popular in the '20s. All the brass doors were removed, cleaned, re-

stalled and polished. The brass light fixtures were removed and cleaned; missing fixtures were copied and replaced. Chrome was removed from restroom fixtures, revealing solid brass pipes and fittings.

The foyer remains intact except for the "new" concession counter. It was originally installed in an old bakery in New York, and when it was placed in the Byrd, even the competing movie houses found reason to send their executives by to "check it out." The display case with the back mirror and counter is a

Front view of the Byrd Theatre, taken shortly after its opening.



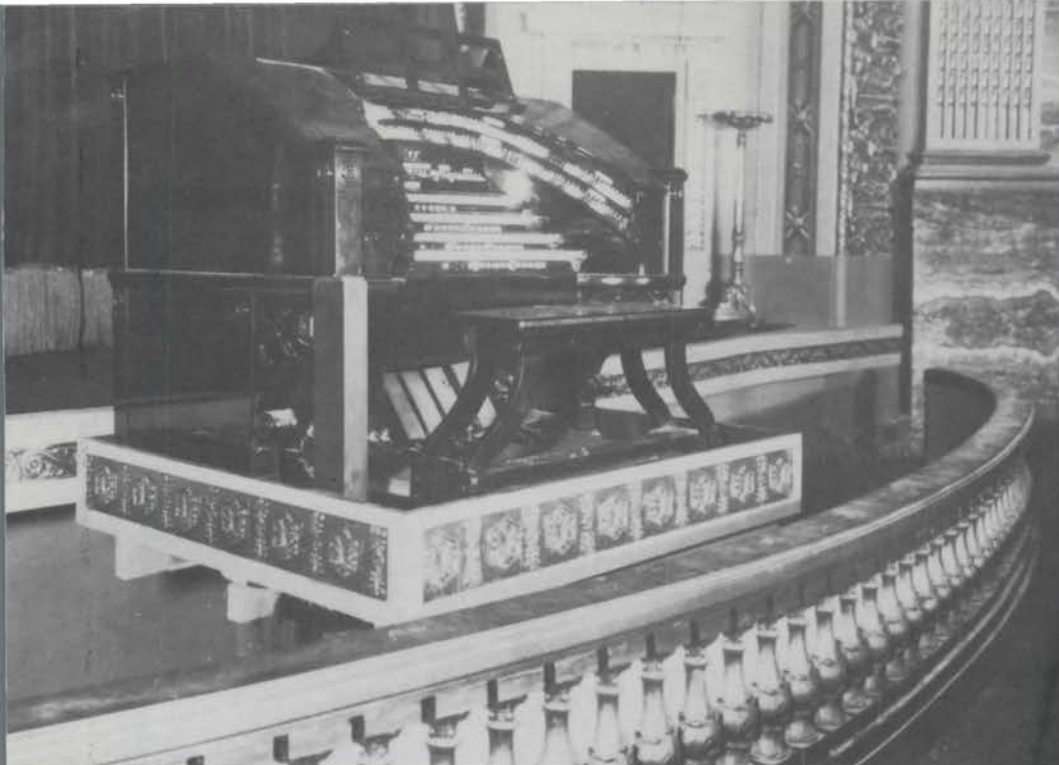

A 1928 photo showing the organ console before it had ever been played. When the stage was extended over the orchestra pit it covered the elaborate fender around the top of the lift on which the console sits. It is still in place but hidden from view.

valuable antique and enhances the elaborate foyer.

All that the auditorium needed was a good cleaning and relamping. A section of the balcony ceiling had to be restored because of previous water damage. Plaster casts were made from existing decorations to replace the damaged plaster. The final touch was replacing the old carpet, which was installed in 1971, with a wine red carpet to match the seats and stage curtains.

The magnificent two-ton Czechoslovakian chandelier hanging in the main dome is equal-

ly as famous as the organ. It contains over 5000 crystals and there are 400 light bulbs in four colors in this massive fixture. It can be lowered for cleaning and lamping. There are a dozen smaller chandeliers throughout the building and 30 crystal wall sconces. Today the Byrd is more colorful than ever and better lit than when it opened. With its seating capacity of 1390, it is by no means one of the largest theatres in the country, but it is certainly one of the most beautiful. William Byrd, founder of Richmond, would be pleased with his namesake.

Taken just prior to opening night, this photo shows the massive dome and chandelier, as well as the original inner proscenium which was covered in the 1950s with a Cinemascope screen.



The Byrd's 4/17 Wurlitzer Hope-Jones Unit Orchestra is one of the finest examples of an original in-theatre instrument that can be found. The instrument has been played regularly since opening night, except for a few years during World War II. Opus 1948 shipped from the Wurlitzer factory in 1928, the instrument is totally original except for a Post Horn rank added in the summer of 1985.

The huge mahogany console rises majestically from the center of the stage on its original Peter Clark lift. The Main and Solo pipe chambers are directly above the center of the stage behind a golden grille. A Grand Piano and Marimba Harp in boxes to the left and right of the stage are played from the organ console.

This organ is known throughout the world for its richness of sound; the organ's many voices literally cascade from above the heads of the audience. By present-day standards, the organ is probably heard by a paying audience more than any other in-theatre instrument remaining. It is played every Friday, Saturday and Sunday for two shows each night by current staff organist Lin Lunde. The organ is in excellent condition because of a dedicated crew and its being played almost every day, either for practice or performance.

Many recordings have been made on the organ, but those made by Westminster featuring Dick Leibert are the best-known. Leibert was organist at Radio City Music Hall at the time and was brought to Richmond for two weeks to make a series of recordings.

When the theatre opened the house organist was Carl Rhond, assisted by Velma Beck and Winston Neville, who was brought from the Colonial Theatre in Richmond. Eddie Weaver played at the Byrd for many years before its temporary closing. He became a very popular Richmond institution with his concerts featuring sing-alongs and "trips through the organ" to illustrate its many voices. Eddie was enthusiastically received by a virtually full house when he returned to the Byrd in October 1985 for his first Richmond concert in several years.

Current staff organist, Richmond's own Lin Lunde, is again making the Byrd organ known in the Richmond area. Lin has accompanied four silent pictures in the last 18 months, including *Waxworks* with four showings; *Wings*, which had six showings; *The General*, which ran a week with two matinees; and *The Eagle*, which had one showing. Walt Strony accompanied *The Son of the Sheik* for one showing. Concerts have been presented by Walt Strony, Ron Rhode, Lowell Ayars and Ty Woodward, as well as by Eddie Weaver. Lin Lunde continues the Byrd tradition of educating new theatre organists — he now has a student who is learning to play the mighty Wurlitzer, just as Lin learned to play it as a pupil of Eddie Weaver.

Today the Byrd is a successful repertory theatre presenting the best the studios have to offer. Duane Nelson is the young man responsible for every aspect of managing this huge undertaking, from the selection of the films to the selection of the French pastries and gourmet popcorn. He runs a tight ship,



The Byrd lobby, showing the original fountain, which contained fish. It was removed to make room for the "new" concession counter.

and is eagerly waiting to greet you at the Byrd.

Going to the Byrd is more than going to the movies — it is a "happening"! A handsome doorman in black tie and tails greets each guest. Pretty young women dressed as flappers right out of the "roarin' '20s" dish up the popcorn, French pastries, sodas and coffee. The show starts promptly with a color cartoon or old newsreel after Lin has entertained the audience on the Mighty Wurlitzer complete with a spectacular light show.

The present owners are to be commended for keeping such a valuable bit of Americana open to the public so that people today, who have been reared on the idea that movies are either shown on the television screen or in a cinder-block building, can actually be a part of the great experience of going to the movies "'20s style"! □

Lance Johnson's Troubleshooting Guide Quiz Question

One of the stop keys is dead at the console. Where would you look for the source of the trouble?

Answer on page 42.

Questions and Answers

Lance Johnson will answer readers' technical questions by telephone. He can be reached at 701/237-0477 from 8 a.m. to 5 p.m. Central Time Monday through Friday, or in the evening from 6 p.m. to 10 p.m. at 218/287-2671. □

AN ENGINEERING BREAKTHROUGH!

The famous TROUSDALE digital tape player can now be attached to *any* organ! Thanks to this new development, anyone can now enjoy the musical sophistication previously available only to Trousdale system owners such as George Wright, Sandy Fleet, Jasper Sanfilippo, etc.

Noted organ enthusiast Paul Van Der Molen, one of the first owners of the new Trousdale compatible digital player, says, "This player has doubled the enjoyment of my 3/18 Robert-Morton. You were a pleasure to do business with and your service is second to none."



- Records *anything* organists can play with *no limitations*: every key, stop change and swell shade movement is recorded with incredible precision, up to 120 times per second.
- Recordings may be played back exactly as recorded . . . or at half the original speed . . . or at *double* the original speed . . . opening a world of possibilities limited only by your imagination.
- Over-dubbing or multiple-track recording is a standard feature at no extra cost. Make your own multi-handed arrangements with no loss of fidelity, thanks to the magic of digital precision.

For further information, contact
Dave Junchen
280 E. Del Mar Blvd.
Suite 311
Pasadena, CA 91101
818-795-2898

The Phoenix Festival Was Fantastic!

by Grace E. McGinnis



Bill Brown leaves the console of the Phoenix Organ Stop Wurlitzer after playing for the Jam Session.



Ron Rhode at the console of the Mesa Organ Stop Wurlitzer acknowledges the applause of his audience.

Walt Strony chaired the festival as well as playing a concert at the Phoenix Organ Stop.



From registration to Rawhide, the weekend in Phoenix was nothing short of remarkable. There was time for relaxation, for socializing, for pleasant dining and for some unexcelled organ music. The Embassy Suites Hotel was distinctive, and the service was first class; free breakfasts were served each morning and free cocktails were available from 5:30 to 7:00 each evening. The five-story atrium lobby was also a lounge where we could meet and visit at any time. Large pools with goldfish watching us and massive tropical plants brought the outdoors in and made the whole area rather like a park. A computerized fountain in the center kept changing from soft to loud splashing and necessitated the modulation of conversation to compensate.

Bus-boarding time on Friday afternoon brought a delightful surprise. There was our friend from the Indianapolis Convention, Alden Stockebrand, orchestrating the loading process and moving the buses smoothly out into traffic for the ride to the Organ Stop Restaurant. We were certain, at that time, that transportation would be well-timed and efficient. And it was!

Affable Tom Hazleton opened the festivities with his unique classical and traditional arrangements and flamboyant stylings. The 4/33 Wurlitzer in the Phoenix Organ Stop has an unenclosed Trumpet en Chamade above and behind the audience, and those of us who did not know this and sat in the back of the room fairly flew out of our seats at Tom's first fanfare. It took a bit of time for us to settle down and enjoy the rest of the program, but we did!

The Friday evening program for our group was Lew Williams at Bill Brown's 5/22 Wurlitzer. Lew's program reflected the relaxed

and unhurried mood which prevailed in Phoenix. There was even time during intermission for theatre organ buffs to tour the chambers, and Mr. and Mrs. Brown were most gracious hosts. Just enough rain fell on the patio and pool outside the living room that those from the Northwest felt quite at home.

Friday's third event was a Jam Session at the Organ Stop in Mesa. Ron Rhode, one of the owners of this restaurant, opened the session with a lively "Singin' in The Rain." Other participants were Patti Simon, Walt Strony, Kevin King, Andy Crow, Jane McKee Johnson and Homer Johnson. Ron Rhode then introduced soprano Barbara Clark, one of their employees, who delighted the audience with several vocal selections accompanied by Ron. The evening ended with a wake-up rendition of "Stars and Stripes Forever," which sent us back to the hotel with the feeling that we had just experienced a musical smorgasbord; we were happily and pleasantly stuffed!

Saturday morning brought one of the most interesting programs we have attended in a long time. Ron Rhode interviewed Betty Gould, a truly bright and charming early theatre organist whose stories and commentaries could have held our attention for the entire morning. One would hope that this lady's words might be recorded and/or published to reach the widest possible audience. Following this captivating interview, Tim Needler moderated a panel discussion with four of the festival organists, Ron Rhode, Walt Strony, Lew Williams and Lowell Ayars. Questions were submitted in advance, and Tim moved efficiently to cover as many as possible in the time allowed. The artists had some strong (and

L to R: Tim Needler, Lew Williams, Walt Strony and Lowell Ayars in a panel discussion of questions submitted by attendees.



most interesting) opinions about how advance technology will affect the theatre organ scene, what we can do to keep theatre organs alive and well, what annoys performing artists and how they cope with different organs on which they perform around the country. This type of presentation provides much food for thought for those of us who love the theatre organ.

Our afternoon entertainment was a concert by Walt Strony at the Phoenix Organ Stop. Walt and this 4/33 are so compatible and his arrangements are so expressive that we were reminded again of the theme of this festival,



Lowell Ayars at the First Christian Church 2/9 Wurlitzer.



Carlo Curley arrives at the Embassy Suites Hotel prior to his concert at Valley of the Sun Center with Lyn Larsen.

Tom Hazleton opens the Phoenix Festival at the Phoenix Organ Stop Wurlitzer.



“A Celebration of Excellence.” Walt made it just that!

That night our group went to the First Christian Church where Lowell Ayars performed on their 2/9 (not quite finished) Wurlitzer. Lowell has a gift for making small organs sound just right, and his selections were most appropriate for this instrument; he played medleys which were gentle, mellow and sentimental.

The second Jam Session filled the Phoenix Organ Stop and was set off by Ty Woodward with a rollicking number from *A Chorus Line*. ATOS President Jack Moelmann then took the console followed by Kurt von Schakel, Lew Williams, Bill Brown and Don Myers. The Organ Stop owns some glass sing-along slides and we sang to the accompaniment of Lew Williams. ATOS members can sing, too!

Sunday morning was clear and sunny, and the ride to Mesa allowed us to appreciate all of the mountains surrounding Phoenix and to realize why so many people opt to winter there. Ron Rhode was in top form at the console of the Mesa Wurlitzer, and an added feature, a brilliant young jazz harpist, Park Stickney, brought a sparkling dimension to the usual concert format. His “Take Five” was a real show-stopper.

The Valley of The Sun Center was the locale of the Lyn Larsen/Carlo Curley Grand Finale of the Festival. Lyn at the 3/16 Wurlitzer and Carlo on an Allen 8000 rattled the rafters with their duet of Leroy Anderson’s “Fiddle Faddle.” At this program Convention Chairman Walt Strony presented ATOS President Jack Moelmann a check for \$1000 to add to the fund for the Young Organist Competition. Larsen and Curley wound up the affair with a matchless *William Tell Overture*. A spectacular finish to a weekend that was close to being perfect.

The Afterglow found us at a Western movie set — or a reasonable facsimile of same — for a genuine Western Barbeque. A three-piece combo provided musical atmosphere as hardy conventioners stowed away steak, beans, salad and (What’s this?) French fries. Western hospitality was the name of the game, and some 300 enthusiasts had been filled with music, food and fellowship. What more could we ask?

Walt Strony and his crew deserve the highest kudoes for this production. There was music for every taste by some of the finest organ-

ists in the country on pipe organs that are lovingly cared for by skilled technicians. Could there be a more auspicious combination? Madeline LiVolsi made registration a pleasure, and Alden Stockebrand conducted the busses like the maestro he is. Chapter hosts and hostesses were always available to answer questions and help us find the rest rooms. Bill and Barbara Brown opened their home to 300 pairs of wet feet and eager ears; Phoenix is fortunate to have friends of this calibre who support and promote theatre organ. There are certainly others who made this festival successful, and to all of them we wish to express our gratitude for an unforgettable, fantastic three days.

GRACE E. MCGINNIS □



Lew Williams and Bill Brown in front of the Browns’ Wurlitzer.



Theatre organist Betty Gould accepts roses from Ron Rhode after being interviewed for the ATOS guests.

ATOS President Jack Moelmann accepts donation for Young Organist Competition from Phoenix Festival Chairman Walt Strony.



EDWARD SWAN

Theatre Organist

by Lloyd E. Klos

Ed. note: We are indebted for this story to Lonnie C. Roach, whose parents winter in Florida near the home of the subject, and to Mabel Roach, who secured the pertinent information.

Born at the turn of the century, Edward Swan is a native of Livingston, Montana. He also lived in Anaconda and Butte, and it was in the latter place where the youngster began piano lessons at age nine. Later on, he played in dance bands in the Butte area.

Still a young man, Ed was invited to play piano in the 900-seat American Theatre in Butte. It was one of his great lifetime thrills when he sat in with this group of professional musicians of the theatre's concert orchestra whom he had heard and admired since boyhood. He was especially adept at sight-reading, being able to read and play any piece of music given him.

The matinees at the American were from two to five, and the evening performances from seven to midnight. The orchestra played almost constantly with a ten-minute break every hour. Occasionally, the director would see a preview of a new film so that he could select and arrange the proper music for the picture's screening, but more often the band had to improvise as the plot unfolded.

In March 1917, the theatre's management purchased a 3/7 Wurlitzer Opus 126. The owner, Frank Baily, wanted to send Ed to a music academy to learn to play an organ. The musician was always sorry afterward that he didn't seize this opportunity. Baily had helped other young people in their quest for higher learning.

As it turned out, Ed Swan was mostly self-taught as an organist. Basic principles were learned from Henry Francis Parks, who was the theatre's concert organist. Management wanted Swan to take Parks' job but he refused, simply because he didn't care to take the job from someone else. This custom of replacing older musicians with newly trained organists was done quite often, according to Swan. The newcomers' salaries were smaller!

Ed's next job was at the 3000-seat Rialto Theatre in Butte. The organ was a large four-manual White organ, with echo and open di-

visions, a good selection of traps, and three 32' pipes, probably costing around \$50,000.

The Rialto also had a pit orchestra. Ed played the feature movie, and the orchestra did the two-reel comedy and the newsreel. It was here where our subject really learned how to improvise. Such great pictures as *Ben Hur* were featured during this period. In one of the battles of the classic, he remembers that he really played up a storm! He employed a sheet metal attachment, and when he put his foot on low C# it shook the building! He had to stop using this at management's insistence. He says that he seldom used the open division of the organ, as he had no control of the sound.

While he and his family were in Butte, he

also furnished piano accompaniment at the Ansonia Theatre, a narrow building a block long. He also played piano at the Orpheum Theatre, a ten-cent house. Playing in those theatres meant long hours of work.

Ed Swan's next engagement was in the American Theatre in Salt Lake City in 1923. As a child, he had visited relatives in the city and had been to the American to hear a concert played by a 50-piece orchestra. The American had a three-manual hybrid organ, a combination of Möller, Kimball and Robert-Morton. The theatre brought in Orpheum Circuit vaudeville, with live acts featured on the bill with movies. Ed played for the movies and a small orchestra accompanied the vaudeville.

Ed Swan poses at the 4/26 Robert-Morton console in the Balboa Theatre, San Diego, in 1925. He feels that this instrument was the finest theatre organ he ever played. An echo division was installed over the balcony. (Swan Collection)



The house had a large lobby with a beautiful glass stairway leading to a "Dansant," a large dance hall over the lobby. Those who attended the evening show could dance afterwards.

In 1925, the Swan family moved to Los Angeles where he became affiliated with Fox West Coast Theatres. He was first employed at the 1600-seat Balboa Theatre in San Diego. The organ was a 4/26 Robert-Morton, which he says was the finest he ever played. It had an echo organ over the balcony.

The Balboa was affiliated with the Orpheum Circuit, and Ed played the features, while the small orchestra did the vaudeville segments. Sometimes Ed also played the organ or piano with the orchestra, and his playing time lengthened to ten or 12 hours a day. Unable to use a cushion on the bench, he has memories of the hardness of the wooden benches! He was always dressed in a tuxedo in those days.

When radio was growing in popularity, he played a daily noon concert at one of San Diego's radio stations.

In 1927, he returned to Los Angeles where he played for two years at the 1454-seat Rosemary Theatre in Ocean Park. The organ was a 2/9 Wurlitzer, installed in 1925. There was no orchestra, so Ed provided all the music.

Next came an assignment at the 1200-seat Criterion Theatre in Santa Monica. It had a 2/9 Wurlitzer, later augmented with three ranks. Again, Ed was the sole music-maker.

Ed Swan's connection with the Fox organization continued, but he now ventured into a new field. He became employed at Fox Studios where in 1928, they had purchased a three-manual special Wurlitzer. Ed did a goodly number of recordings for the movies, and he is of the opinion that some of these are still there in storage.

Occasionally, he would sit in on a screening of a newly released film, and then make arrangements. He was sent to several theatres to accompany the film. It was a good paying job and he remembers being sent to the Egyptian and Chinese theatres (3/15 Wurlitzers) in Hollywood, and the Metropolitan (4/32 Wurlitzer) in Los Angeles.

The Metropolitan's organ, he said, was the most difficult to play. The console, which was in the pit, would be elevated while he played. It was difficult to hear his own sound!

He also earned a little pocket money by serving as an extra in some movies, and he has some stills to confirm this.

His final theatre engagement was in 1930 at the Carthay Circle in Los Angeles, playing a 3/11 Wurlitzer, while big pictures such as *All Quiet on the Western Front* and *Hell's Angels* were shown. In 1931, the theatre was closed and the silent movie era was over for him and many of the organists. However, the Carthay's owner wanted to retain his lease, and in order to do so had to reopen, providing entertainment every day.

Ed Swan was engaged to play an hour's concert, starting at noon, which he did for several months. He also played with several orchestras, such as those of Carl Elonar, Abe Lyman and George Stollberg (later Georgie

Stoll). He also filled in for Evangelist Aimee Semple MacPherson's organist.

It is interesting to note that when Ed Swan played in Montana theatres, his salary ranged from \$35 to \$50 a week. When he concluded his theatre organ career, he was earning \$250 a week, which was considered an astronomical sum during the early days of the Great Depression.

Having played a theatre organ and being a member of the Los Angeles Theatre Organ Club had opened many doors for him and his wife to meet some fine people. He was organ-

ist for the annual International Air Stream rallies for many years.

Following his career as a professional musician, Ed joined the Los Angeles Police Department, which he thoroughly enjoyed for 30 years.

Now living in retirement in Homestead, Florida, he has a Hammond in his mobile home, and continues to play for his own enjoyment. He has watched with interest the progress and popularity of electronic organs through the years. Now in his eighties (1981), he is living a happy and useful life. □

ATOS Archives Catalog Is Published

Vern Bickel, Curator of the ATOS Archives/Library, has completed the lengthy task of cataloging all items in the archives collection. A new and complete Archives Catalog is now available to members. If you are interested in obtaining a copy of the new catalog, send a check in the amount of \$15.00, made payable to ATOS Archives, to Vernon P. Bickel, Curator, 1393 Don Carlos Court, Chula Vista, California 92010.

A number of members have contributed items to the archives collection this year. A special "Thank You" is expressed to the following persons:

Bill Alexander
Charles and Betty Baas
Tom B'hend
William Fearnley
Esther Higgins
Harry J. Jenkins
Russell Joseph
Dr. John W. Landon
Timothy S. Needler

Claude V. Neuffer
Miles J. Rudisill, Jr.
Karl C. Saunders
Alfred Turnbull
Lorin J. Whitney

Because of the generosity of these individuals, the Archives/Library has continued to grow. However, our collection is far from complete. We need your help. Donations of items related to theatre pipe organs, organists and theatres, plus music, recordings and memorabilia are urgently needed. Please send such items to the Curator of the ATOS Archives. Remember, all contributions are tax deductible.

During 1985, Preston M. "Sandy" Fleet donated 100 sets of the McMains Theatre Pipe Organ Tapes to the archives, to be used for fund raising. We express our sincere appreciation to "Sandy" for his support. At this writing, a few sets of the McMains Tapes are still available. If you want a set of these tapes, order them soon. This may be your last chance to obtain them. □

RAMADA® HOTEL

HOTEL AND CONVENTION CENTER
Albuquerque, New Mexico



HOME OF THE FORMER NEW YORK ROXY
KIMBALL ORGAN CONSOLE

Organ restoration by Hockmuth-Stankey Organs, Inc., New Lenox, Illinois

RAMADA® HOTEL

6815 Menaul NE • Albuquerque, New Mexico 87110
(505) 881-0000 Reservations: 1-800-528-1234

Five Manual Kimball Roxy Theatre Console with 28 ranks now owned by Phil Maloof.

Before making any suggestions that might help an organ enthusiast repair a damaged pipe I want to pay a tribute to a person who, in my opinion, is one of the great artisans of the pipe organ industry — THE VOICER.

Many organ fans confuse voicing organ pipes and tuning organ pipes. They are two separate functions. Organ tuning is done after the installation has been completed. The tuner sets the temperament and tunes all the stops to the temperament octave. He also does the finishing, by which is meant adjusting the volume of the pipes in each stop so some tones are not louder or softer than the others. Finishing is most important with reed stops.

A voicer works in the factory or in a pipe shop which is operated separately from an organ factory. He has a voicing room connected with the pipe shop. It takes several years of experience combined with an artistic temperament, a natural ear for tonal quality, great accuracy of workmanship and plenty of patience. He usually starts with such work as weighing metal — zinc, tin or lead — into exact proportions for metal pipes. He helps with the casting, solders metal pipes together or glues on sides around the blocks of wood pipes, always observing and studying the art of the voicer. A voicer usually receives the pipes from the pipe shop in such a condition that no sound can be produced from them. The voicer makes the pipe speak.

The voicer of metal flue pipes adjusts the shape of the languid, which is the flat piece of metal that lies horizontally just inside the mouth, determines the width of the mouth and adjusts the upper and lower lips. He nicks the front edge of the languid like the teeth of a saw, some with shallow nicks very close together and others much deeper and farther apart. Nicking creates a series of air columns instead of a solid stream.

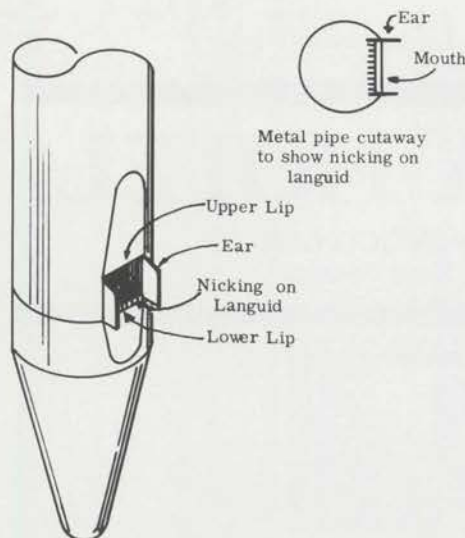

Fig. 1. Parts of metal pipe (mouth).

In wood pipes the voicer adjusts the upper and lower lips and the block. The block is the same to a wood pipe as a languid is to a metal pipe. The voicer by these operations creates the timber or tonal quality, such as French

repairing and voicing damaged organ pipes

by Dan Barton, Organ Builder

Illustrated by Tony Provenzano

Horn, Oboe, Violin and many others. The voicer makes the pipe speak with many of its upper harmonics or partials to produce the tonal quality of Strings, Trumpets and Tubas. He makes pipes speak with no harmonics or partials to produce the tonal quality of Flutes, Bourdons and foundation tones. The pipe with only a part of its harmonics or partials becomes a Diapason. By suppressing certain partials and using only one partial the voicer creates the tone quality of the Clarinet or Oboe. The voicer uses small nicks close together for String tones, deeper nicks farther apart for Flute tones. With reed pipes the voicer adjusts the shallot, which is the partly cut away brass tube that carries the reed. The voicer determines the thickness, width and vibrating length of the reed. Without doubt, the greatest precision of all the voicer's art is the curving of the reed. He curves small reeds with his fingers, exactly the right curve to create prompt speech, no rattle and with correct tonal quality, an exhibition of experience, skill and patience. The large reeds are curved on a curving plate, sometimes called a curving block.

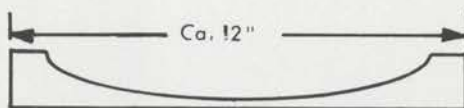

Fig. 2. Reed curving block (side view).

If you want an excellent demonstration of harmonics and partials, secure one of a pair of high grade cymbals such as used in concert bands. Hold the cymbal by the strap and hit the outer edge a sharp blow with a padded beater, such as used to play a bass drum. You

will hear a prime tone and a multitude of overtones. The overtones are harmonics and partials of the prime tone.

I repeat, a good voicer represents years of experience combined with an artistic temperament, a natural ear for tonal quality, great accuracy of workmanship and plenty of patience. He is indeed a great artisan. His value to organs is too often overlooked.

The organ enthusiast has no need for such qualifications, for he will never be confronted with organ pipes directly from a pipe shop that must be made to speak before they can be used, but enthusiasts do encounter voiced pipes that have been damaged so they do not speak properly, or perhaps not at all.

Fixing damaged pipes so they will speak is not easy, but here is how you can try.

Metal flue pipe: If the mouth is badly damaged and the languid (the horizontal piece of metal inside the pipe) is badly bent the pipe cannot be repaired. The languid is soldered inside the pipe during the process of manufacture and cannot be replaced.

Metal flue pipes are made from either common or spotted metal and are easily damaged. If bent only slightly near the mouth the pipe will lose its speech. The tools needed are a Lip Raiser and a Languid Depressor. To make the tools use two old table knives or other metal as thin as a knife blade. If the metal is steel, draw the temper by heating. Cut the blades off square at the end. Bend the end of one blade to a right angle 1/4 inch from the end. The flat blade is the Languid Depressor, the bent blade the Lip Raiser. Use an undamaged pipe for a pattern.



Fig. 3. Metal pipe repair tools made from detempered table knives.

The languid must be in a position near the lower lip to provide a slot through which the stream of air is directed so it strikes square against the upper lip. Usually the trouble is caused by the stream of air passing in front or in back of the blade of the upper lip. Use the Languid Depressor to move the languid slightly up or down and the Lip Raiser to move the lower or upper lip in or out. If the pipe has no speech or if it flies off its speech or sounds its octave or if the pipe is slow to speak, try pulling the upper lip slightly outward and move the languid slightly downward. If no results, reverse the procedure. Take it slow and easy and work carefully on the languid. If the solder breaks loose and the languid becomes loose in the pipe you are done. Do your practicing, if possible, on pipes which don't matter should you ruin them.

If the upper part of the pipe or resonator is badly damaged, try this experiment. Cut the resonator off and replace it with a heavy tin tube. Solder the seam of the tube and solder

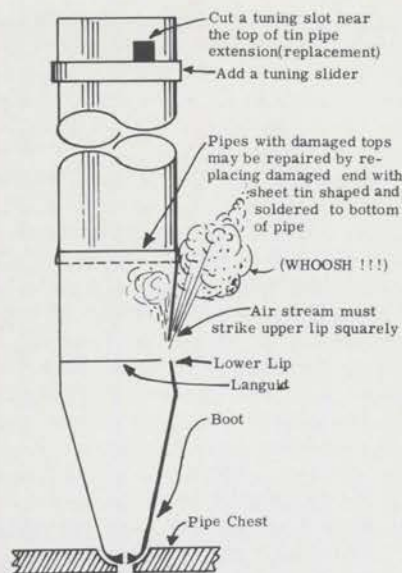

Fig. 4. Metal pipe repair (shows languid, upper and lower lips which may be adjusted to direct air).

the tube to the stub of the organ pipe. It should be slightly longer than the original pipe. Cut a tuning slot in the top. Make a tuning slide of tin so it can be moved to lengthen or shorten the tuning slot. If the slide is not spring material fasten it with a piece of tape. You will not recover the original tone quality, but you will have a speaking pipe which is better than a blank note. Soldering pipe metal is an art unto itself. It melts at temperatures not much above the melting point of solder. Therefore, soldering must be done rapidly and with a light touch. Practice on some scrap pipe metal before tackling a pipe intended for use.

Reed pipes: The shallot is the partly cut away brass tube that carries the reed. The reed block is the metal part which holds the shallot and reed. The wedge is the wedge-shaped piece of metal or wood which holds the shallot and reed in the block. Reeds are also designated as reed tongues.

Reeds can be replaced. Secure some spring brass exactly the same gauge as the damaged reed. Secure enough brass for several reeds. You may need several before you hit the mark. Cut a reed using the damaged reed for a

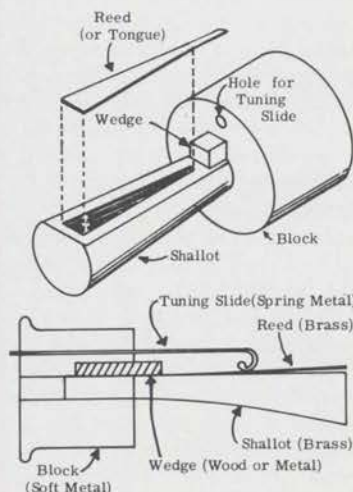

Fig. 5. Reed pipe sound generating mechanism.

pattern. You can also use an adjoining pipe's reed for a pattern. After the reed is cut it must be polished to make sure it is free from grease, corrosion or other substance. The next step is to curve the reed. This is done with a curving block. The curving block can be obtained from an organ supply company. The reed is held on the curving block at the small end. With a tool such as a small half-round chisel or shank of a screwdriver press the length of the reed starting from the small end. Use an adjoining pipe's reed to judge the proper curve of the reed. Experiment by curving small reeds with your fingers. Mount the reed on the reed block and hold the lower end down. Hold the shallot and reed to a light. If you see light between the reed and shallot your experiment did not succeed. Try again. Keep your hands dry when handling reeds and never blow your breath on a reed. You will start corrosion that will eventually spoil the reed.

Wood pipes are not so easily damaged as metal pipes and a first class "do-it-yourself" man can replace a damaged part or even build a new pipe. Make sure the block languid, which is inside the pipe near the mouth, is exactly the same size as the original block. Some organ pipes have two languids but they will

only be found in very large organs where great volume is necessary. The inside surfaces of wooden pipes are sized with diluted glue, the outsides may be varnished or lacquered, if desired.

Keep in mind that repairs undertaken by organ buffs must necessarily be classed as experiments. Don't be too disappointed if you don't get the desired results. Just remember the qualifications of a voicer: 1) artistic temperament, 2) a natural ear for tone quality, 3) great accuracy in delicate workmanship, 4) the patience of Job and 5) several years of apprenticeship. There are no short cuts and it is most unlikely that these abilities will be found very often among the scores of organ enthusiasts now confronted with the problems of such repairs. If a reasonable number of experiments result only in pipes more mangled than before, give up before you are branded a "pipe destroyer." In this case, turn the job over to professionals. But even though you have ruined a few pipes beyond repair you will also have learned something of the working of pipes. So, have fun — and gain some invaluable experience. □

This article is reprinted from *Post Horn*, April-June 1963.

Long Center Schedules Four Favorite Organists

The 1985-86 Long Center Organ Series offered the Springdale Music Palace artist, Karl Cole, and his friend Anna Chovie for the opening concert on November 1. His concert attracted a large and very responsive audience.

Next in the series, on March 1, will be Tom Wibbels, the versatile artist who had his audience calling for "More!" at his Chicago Convention concert.

Tom Hazleton returns on May 4 for his fourth appearance at the Long Center in Lafayette, Indiana. During the Chicago Con-

vention his was one of the top programs when he played the six-manual Barton in Chicago Stadium.

Ken Double will conclude the series on June 7. He dedicated the organ in February of 1981, and has since played the concluding program to a full house for each of the organ series.

Ticket information may be had by phone at 317/742-5664, or by mail at Long Center for the Performing Arts, P.O. Box 13, Lafayette, Indiana 47902. □

Karl Cole and his friend Anna Chovie at the Long Center console.

(Frank J. Oliver photo)



Another Opening ... Another Show!

by Dr. Larry Warkintin

The Moore Memorial Wurlitzer organ will play for the first time in the Special Events Center at Fresno Pacific College on March 7, 1986. For this private, Christian liberal arts college in Fresno, California, it will be a major first. The event, called OPENING NIGHT, will be heralded in true show-stopping style with beacon lights, a jazz band, a delicious dinner with singing waiters, celebrities, and a concert by nationally recognized organist Tom Hazleton.

But this will not be the first "opening night" for this venerable Wurlitzer. Like many old theatre pipe organs, the Moore Memorial Organ embodies a fascinating history. Its first opening night came during the 1920s when the console was installed in the CBS studios in Hollywood. There it played background music for such radio programs as the "Amos 'n Andy Show."

Later the organ was sold to a Presbyterian church in Fillmore, California, but the Fillmore church actually wanted a more traditional console. Marguerite Moore of Porterville, California, acquired the console for a theatre organ she was building in her home (THEATRE ORGAN March/April 1982).

Mrs. Moore was an active teacher of organ and piano. When she lost her son, Richard, she needed some activity to consume her time and her grief, so she naturally turned her energy to a musical task. She decided to build a pipe organ in her den. Over a period of 20 years she bought, borrowed and traded parts for her project. Soon her den was overcrowded, so she had her patio enclosed.

Her project was getting national attention. At a convention of the American Theatre Organ Society, of which she was a long time member, she overheard a group inquiring if

anyone knew "that crazy woman from California who was building her own organ." She piped up "That's me." By 1980 the organ had grown to 18 ranks and more than a thousand pipes, including parts of theatre organs from San Diego to Santa Cruz.

Early in 1980 Mrs. Moore learned that she would soon die of cancer. She turned her remaining energy to finding a suitable home for the organ. She wanted it to be used for instruction and entertainment. Through a chain of acquaintances which resembles the underground railroad for theatre organists, she contacted Richard Cencibaugh of Fresno. Richard contacted Fresno Pacific College because he knew of its strong music program. College leaders told him the project was too expensive and unrealistic. It wouldn't work. But the chairman of the music department couldn't let go of the dream so easily. Almost out of the blue a major donor came forward. The families of Ron and Don Underdown pledged to contribute the first \$20,000 necessary to move the organ. The project was off and running. Few people at the Fresno Pacific College could have imagined the amount of community involvement that lay ahead.

During the summer of 1981 the work began with dismantling of the Porterville installation. Frank Caglia of Fresno donated space for storing the console, blower, shutters, pipes, cables and various traps and percussions which had been crowded into the Moore home. Harvey Kroeker, a skilled carpenter, gave hundreds of hours to the project. It was he who worked through the engineering details for construction of the chamber in the college Special Events Center.

The chamber is hung from the five-foot-thick laminated beams which span the Center. It cantilevers nine feet out and runs 40 feet wide along the wall. The chamber is only 13 feet tall, which required the longest pipes to be installed horizontally. It is divided into three sections, Solo, Percussion and Main. The three sets of shutters permit a high degree of dynamic control. The exterior of the chamber, also designed and built by Kroeker, is covered with a grille of vertical dark-stained slats which match the dark wood highlights of the auditorium-sports center.

The Center is large: its 415,000 cubic feet of space can seat 2500 people. This required some adjustment of the organ's capability. A 7½ hp blower was placed in a chamber on the roof of the building. It provides the necessary 15 p.s.i. of air pressure to make the pipes speak with authority. Two new ranks (English Horn and Brass Trumpet) were added to provide needed brilliance.

A major decision was made early in the project to completely update the circuitry of the old Wurlitzer. This added more than \$10,000 to the cost but is well worth it in terms of performance capabilities and maintenance. Robert Trousdale of Santa Ana, California, agreed to create a highly complex multiplex relay system and computer capture combination action for the organ. This intricate system makes use of the best features of modern technology. Lynn Upham of Alameda, California, did the total rewiring of the

Dr. Larry Warkintin at the console of the Moore Memorial Organ at Fresno Pacific College.





View showing the unusual design of the former CBS studio Wurlitzer. The middle row of stops above the top manual was added during the rebuild for the college.

console and connected the Trousdale system with the installed Wurlitzer.

This new approach to wiring in organs is being used today in many pipe organ installations. In laymen's terms, the Trousdale system uses a computer in the console to translate messages such as notes, registrations and dynamics into digital information which can be understood by a computer up in the chamber. The chamber computer translates the digital information back into electrical impulses which then activate pipes, percussions, traps and shades. This efficient system permits registrations and couplings which would be virtually impossible with a traditional system. For example, one may set up a registration which adds a bass voice to the lowest member of any chord. Or one may select a registration which produces a pizzicato attack on a sustaining chord. And all of this requires only a very small cable running from the console to the chamber. For the Moore Memorial Organ this is a decided advantage, as the console will travel as far as 200 feet from the chamber.

Even while the project has been underway, the unique character and history of the organ has been growing. In 1983 the Masonic Temple Building on Van Ness Avenue in San Francisco was scheduled for redevelopment. This meant that its two pipe organs would have to be sold, given away or destroyed. Bay West Development Company, which controlled the San Francisco project, agreed to give the two organs to Fresno Pacific College if the college would pay for their removal. This provided some additional ranks of pipes and also made available some materials for sale to help in the cost of the total project.

The specifications of the Moore Memorial

Organ in its modern reincarnation on March 7 will include 20 ranks of pipes, six percussions and 20 sound effects. In total, 1800 pipes will be controlled from the console, as follows: Pedal — 30 stops; Accompaniment — 51 stops; Great — 65 stops; Solo — 38 stops; nine tremulants; ten general pistons and 67 combination pistons.

The technical work of the installation has been under the supervision of Riverside, California, organ technician, Don Cover. Much of the work has been done by volunteer students and friends of the college.

When Mrs. Moore played the Wurlitzer for the last time in her home during the summer

Installation in the college's Special Events Center. Chamber structure is hung from the two beams, directly above the console.

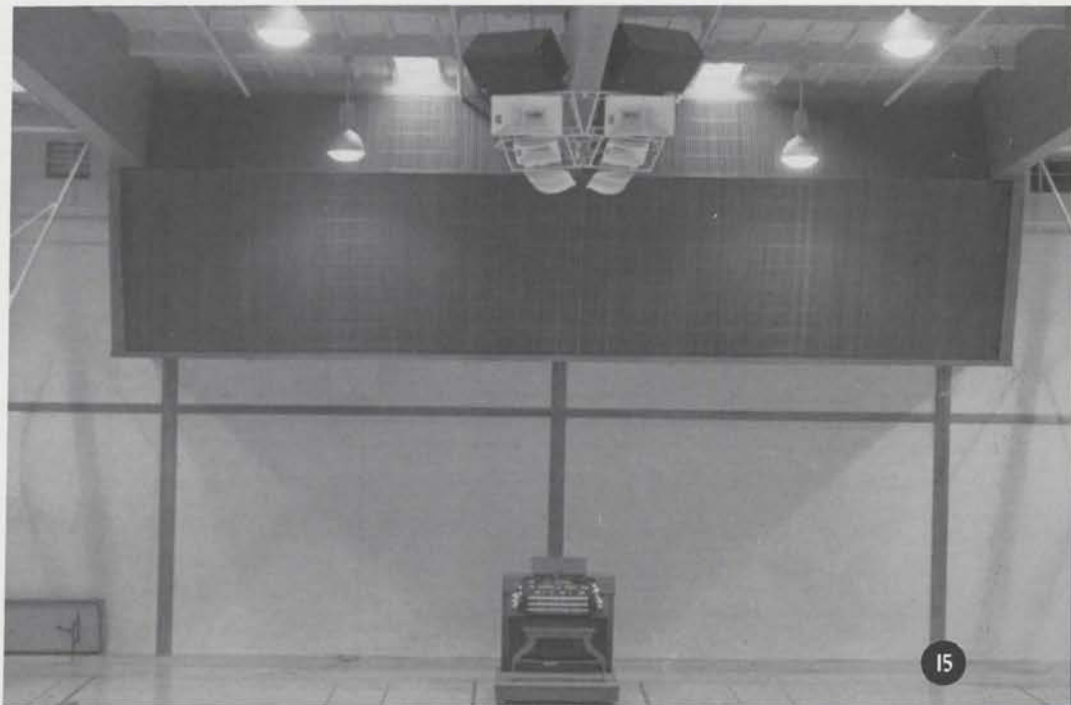

of 1981 she shed a few tears, but she rejoiced that she had found a good home for her life's work. She did not live to hear the organ again. But she had planned wisely for the organ's future. Not only had she found a place where it would be used for instruction and entertainment, but she had also created an advisory committee to look after its installation. The stature of the names in this group is a reflection of Mrs. Moore's active involvement in the organ world. Richard Purvis, Tom Hazleton, Richard Cencibaugh and Richard Villemin have contributed to the project. Gaylord Carter, known for his long colorful history as a theatre organist, also became involved in the project by giving a concert on Fresno's Warner Theatre pipe organ in 1982 to help raise money.

The OPENING NIGHT dinner concert with Tom Hazleton is designed to pay off the remaining expenses and add to the maintenance endowment fund. The endowment project is being encouraged by the enthusiastic support of Eleanor Foerster, daughter of Marguerite Moore.

Elona Kriegbaum, OPENING NIGHT coordinator, has announced a \$25 per person contribution and plans to serve 600 guests. The festivities will feature a theme of early twentieth-century Hollywood. A short Laurel & Hardy silent film will be shown with Hazleton providing organ accompaniment. He will conclude the evening with a performance demonstrating the broad capabilities of the Moore Memorial Organ. His national reputation as organist in church, concert hall and theatre gives promise of an exciting evening.

Seats for OPENING NIGHT may be reserved by calling 209/251-7194, or by writing to Elona Kriegbaum, Fresno Pacific College, 1717 South Chestnut Avenue, Fresno, California 93702.

Dr. Larry Warkintin is Chairman of the Music Department of Fresno Pacific College. He has published a number of musical compositions. □

For The Records

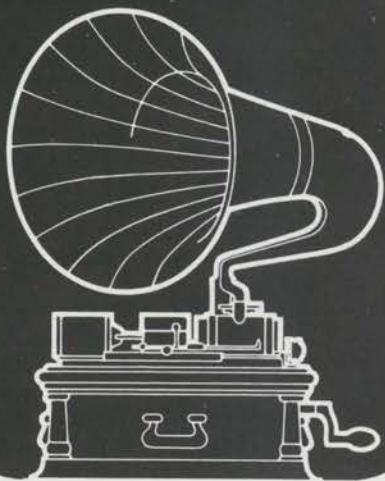

Manufacturers, distributors or individuals sponsoring or merchandising organ recordings are encouraged to send review copies to the **Record Reviewer, THEATRE ORGAN, 3448 Cowper Court, Palo Alto, California 94306.** Be sure to include purchasing information (post-paid price, ordering address) and a photo of the artist which need not be returned.

FIVE ALIVE, Premiere Recording on the Capri Theatre Pipe Organ, Goodwood, South Australia, Digipipe WB 1001. Available from TOSA (S.A.), G.P.O. Box 595, Adelaide 5001, South Australia; price AUS \$12 plus AUS \$2.25 for surface mail or AUS \$7 airmail.

In a corner of the U.S. where bumper stickers proclaim "America's Cup — Don't Leave Perth Without It!" there is a genuine respect for anything the Australians sail in the direction of these shores. Nor should this respect be limited to racing yachts. **Five Alive** is a blockbuster LP crewed by Tony Fenelon, Neil Jensen, John Atwell, David Johnston and Ray Thornley. Any one of the five could wind up "Organist of the Year" in ATOS land one of these days. The digital recording of a fantastic 4/15 sort-of-Wurlitzer is perfection. Generous jacket notes about the artists and organ are interesting, and the front photo of the stunning installation in the Capri Theatre (owned and operated by TOSA) sets new standards for album covers. Bravo, John Thiele! For extra good measure the producer, Wayne Bertram, has assembled the performances in just the right sequence for optimum listening pleasure. There's much in the 14 selections to please every taste. However, rather than following the program, let's consider each of the lively five.

Tony Fenelon is no stranger to theatre organ fans in either the U.S. or Australia and has 14 recordings (four gold records!) to his credit. Oh yes, he happens to be a Medical

Electronics Specialist which provides a steady income! Tony's three selections reveal his awesome diversity of styles. "Anything Goes" gets the novelty treatment with lots of oriental percussions. It is reportedly based on the Temple of Doom arrangement in the recent Indiana Jones movie. A disarmingly clever tour de force, it seems to end much too soon. "When Love Is Gone" is a gorgeous ballad which further demonstrates Fenelon's unerring taste in registrations. Individual voices sing out the many virtues (and no vices) of the Capri installation. "On A Clear Day" brings out another side of this versatile musician. He can swing and do sensational jazz improvisations. It's a honey of an arrangement with a delightful Count Basie touch at the end. These three cuts do nothing to tarnish the reputation of Australia's foremost theatre organist.

Neil Jensen, the youngest of the five, has also toured the U.S. and has two other albums to his credit. Hammond Australia sees that he eats regularly. Neil is their National Marketing and Promotions Manager. His easy swinging ballad "Georgia On My Mind" has an insistent beat, nice block chord harmonies and figures, a rubato interlude which shows off the romantic voices of the organ, then back to the beat for a final chorus which builds skillfully in excitement. For blues feel, Jensen is in a class with Wright and Larsen. "Le Jazz Hot" goes low down with brass accents, then up tempo for Xylophone flips. Percussions are beautifully understated with some nice drum rim shots to get your feet tapping. Variety of tempos include a suggestion of boogie-woogie. Neil never loses control of his registrations and the brassy are kept smouldering. "Nobody Does It Better" has a nice Buddy Cole treatment under the broadly stated blues line. Listen for the untremmed Clarinet riffs. The tune builds to an unhurried climax followed by a quiet coda. This young man has poise and style to burn!

Adelaide-born John Atwell now lives in Melbourne and works as a Research Scientist in Genetic Engineering. So what's he doing playing a theatre organ? Well, among other things Atwell was mainly responsible for the final specifications for the Capri organ and has a record album to his credit. John's arrangement of "Crazy Rhythm" features full organ ensembles with brass accents. He has a '20s flavor to his playing and improvises a neat second chorus which eventually becomes a stomping, gut-bucket boogie. But don't typecast Mr. Atwell. "Wind Beneath My Wings" is a breathy-voiced beguine with 2' Tibia over-ride. John coaxes beautifully soft ensemble sounds from the Capri before he is finished. A third entry "The Match Parade" uses Clarinet and Glock alternating with Xylophone along with some toothsome ensemble ranks to sell the clever novelty piece. It has a comfortable early '30s ambience.

Ray Thornley works for Yamaha in Australia and is a relative newcomer to theatre pipes. This deprivation has left him with a mere seven record albums to his credit and he was only voted "Best Australian Electronic Organist" three years in a row! How is he on

pipes? The first two guesses don't count! "Taming The Tenor" begins with a wonderfully lugubrious "Vesti La Giuba" which quickly relaxes into a Betty Boop-style Charleston with lots of Xylophone pizzaz. It's great fun with untremmed Flutes band organ style, Bird Whistles, and other toy counter goodies. Thornley is very much at home, thank you! "Fame" is a big production number of the movie theme with lots of Cymbal crashes and 16' pedal voices. The first chorus features a Vox/Tibia ensemble, after which he gets down to rock (as in "rock 'n roll") bottom in earnest. State-side pizza organists should try this one on their younger customers if they haven't already. It's great. After such a protein-loaded entrée comes a feathery light dessert, the lovely "Here, There, and Everywhere." Melody lines in the lower registers are toe curling. Tibias, Kinura and tremis are flawless. This could well be the most beautiful tune in the package.

The fifth artist, David Johnston is a Concert Artist for Technics Organs. He provides the only element missing in the album thus far, a wonderful flair for the absurd. His hilarious reading of Leroy Anderson's "Syncopated Clock" proves that one can be genuinely funny without stooping to cornball tricks. David gets only two hearings in the album, but his second, a full length production number "Mack and Mabel Overture," more than makes up for the loss. Spooky Halloween music ushers in "the chase." A Xylophone does the Charleston and a big, fat Posthorn in the lower registers buzzes impressively. Somehow all of this fooling around gets metamorphosed in the hit tune "I Won't Send Roses." Johnston sells it decisively with lush registrations and a final chorus which literally sparkles with Glock accents. For extra fun he sneaks in some snatches from "My Fair Lady" — just to see if you're listening.

Converting one's money to Australian dollars may pose some problems, and the record shipped via airmail makes it quite an investment. But for one of the best theatre organ records of this or any other year it's worth the red tape and added expense. You could, of course, save a bit by having it shipped surface mail. That way you might receive your copy about the time we win back the America's Cup. Just a little levity there, Mates!

WALTER J. BEAUPRE

I'VE HEARD THAT SONG BEFORE, Phil Kelsall at the Blackpool Tower Wurlitzer, EMI Records, Ltd. Available from Phil Kelsall, Tower Ballroom, Blackpool, England. Inclusive price 8 pounds (sterling draft or I.M.O.).

Resident organist at the Blackpool Tower Wurlitzer since 1977, Phil Kelsall has the unique advantage of recording on the major British commercial label, EMI. Thoroughly professional recording engineers have caught the Wurlitzer's richness and clarity with just enough natural reverb to give it grandeur. The variety of selections and playing styles should please even those who think they have had

quite enough, thank you, of the "Blackpool sound" for this century. And there is another big advantage: Phil Kelsall happens to be a very fine musician who has firmly established his own reputation and loyal following. He doesn't need to do Reginald Dixon imitations.

Every one of the 30 tunes in the album is treated with mastery and respect. For example, Phil opens his program with "March of the Mods," written by a local musician Tony Carr. His reading is sprightly and authoritative all the way with meticulous choices of registrations. The tune may be paste, but Phil's setting for it is pure platinum. He's the Glenn Miller of British theatre organists. Errol Garner's gem quality "Misty" gets an equally inspired reading in a style as far away from the Blackpool zip and dash as one can get. It's a gorgeous Tibia solo over untremmed strings with tasteful and original counter melodies. Listen for his pedal line. It's exquisite. So is the brief Glock cadenza at the end.

"Post Time Galop" and "Can Can" blend nicely as a medley with the Tuba Mirabilis doing the solo honors. Even at its bruising pace Kelsall's playing is sharp and squeaky-clean. Irving Berlin's "Play A Simple Melody" is ricky-tick without being a put down. The Piano arpeggios and clever registration changes save "How Deep Is the Ocean" from being just another heavy-handed ballad. Never one to hide a melody line, Phil reserves his subtleties for the left hand figures.

The organist goes for baroque in "Melanie's Minuet" just long enough to show us how much prettier this 17th century tune can be with theatre tremors a-flying. Variations on the Glockenspiel and Piano give way to a plaintive Flute coda. The medley featuring "Nobody's Sweetheart Now" is hardcore Blackpool effervescence, which really doesn't do any more harm than over-dosing on Alka-Seltzer.

Phil Kelsall confesses in his jacket notes that he missed the American epic TV series *Winds of War*. Just for the record, Phil, this reviewer saw the show, and your beautifully dramatic reading of the "Love Theme" is by far its best moment. Robert Mitchum, Ali McGraw and company were no match for those wonderful happenings at the Tower!

A dab of Piano, a touch of Trombone and masses of Tibias help make Leroy Anderson's "Forgotten Dreams" unforgettable. Kelsall claims that his "Tiger Rag" was "heavily cribbed from Reginald Dixon's famous record." Although high on my personal list of tunes which should be studiously avoided by all amateurs and second-string pros, "Tiger Rag" as sired by Dixon out of Kelsall isn't hard to take. If anything, state-of-the-art recording techniques give Phil the edge.

The space age sounds which usher in Side II were generated, we are told, by both 8' Tibias in the treble range. "Telstar" is an exciting bit of nostalgia for those who remember the Tornadoes as well as for this reviewer who never had the pleasure of forgetting the rock group. Phil Kelsall has a talent for making unfamiliar tunes instantly likable. The "Nun's Chorus" from a Strauss opera *Casanova* is a case in

point. Phil interweaves church and theatre registrations skillfully. He can also roast a chestnut such as "Tico Tico" at break-neck speed and a crisp accuracy seldom heard on pipes. It's no longer a samba, but who cares. Other than "Eleanora," which features a combined Piano/Glock registration, the side is "Phil'd out" with trio medleys of well known tunes rationed to a single chorus each on the Wurlitzer. Melodies are correctly played and harmonic progressions are carefully crafted. These are worth hearing — if not listing.

Everything about this album is thoroughly professional, including the photo of Kelsall impeccably attired in white polyester tux and black tie. For those who want to hear the Tower Ballroom Wurlitzer under ideal recording conditions by the organist who knows it best, the only problem will be converting Yankee dollars to pounds sterling for the transaction. Incidentally, Phil Kelsall has made a very successful commercial videotape of his playing at the Tower. Unfortunately British video is not compatible with our VCR'S, so don't try to order a copy. Now THAT would really be a kick to see and hear. Come on, you U.S. theatre organists, let's get with it!

WALTER J. BEAUPRE

"FATS" WALLER AT THE ORGAN
(from piano rolls). No. MHS 4937Y. \$9.50
postpaid from The Organ Literature Foundation,
45 Norfolk Road, Braintree, Massachusetts
02184.

"Fats" Waller! There was no one like him, nor will there be again. Those of us lucky enough to have been his contemporaries have enthusiastic memories of the quality of his music, often amplified by that infectious, humorous personality. During his lifetime he carried on a love affair with the organ. He served as a silent movie organist in his native Harlem. His best remembered recordings were played on an ancient Estey church organ in the Trinity church, Camden, New Jersey, which Victor Records (now RCA) had taken over for use as a recording studio in the mid-'20s. The Estey never sounded very theatrical, but in the mid-'30s Fats played a series of weekly CBS half hour radiocasts on the New York Times Square Paramount Theatre studio organ, the same 4/21 Wurlitzer often recorded by Jesse Crawford. These almost forgotten broadcasts provided Waller with an instrument worthy of his great ability and if anyone recorded them on his Presto 78 rpm acetate disc recorder, we wish he would make them available to the considerable army of Waller enthusiasts. Until now, the only solo Waller on organ records was the Trinity Church discs plus an album made by Waller on an eight-rank studio Compton during a visit to England in 1938. Of course Fats was also known for his piano stylings, ensemble work with Nat Shilkret's Rhythm Melodists and the Louisiana Sugar Babies, and later on the Hammond organ. But to Waller aficionados there were never enough solo organ records by their idol.



Thomas "Fats" Waller

Enter Ronald Curtis, a noted British organist who has some fine record releases to his credit. Ron had some of the piano rolls Waller had produced between 1923 and 1927, and wondered how those distinctive arrangements would sound on organ. Could such a transfer be made and still maintain the Waller character? Curtis has a four-deck Compton in his studio at Darcy Lever, Bolton. To make it brief he had an 88-note roll player hooked into the organ circuitry. The idea worked perfectly. The enlarged ten-rank organ (plus a Wurlitzer Tibia) provides a very suitable palette for the Waller music but not until Ron had studied all available Waller recordings as a guide to registration and dynamics. The result has a better over-all sound than the Camden Estey and a more satisfying sound than the HMV Studio Compton. Curtis has done much to adapt the combinations used to the Waller style, including Waller's liking for non-trem'd 4' Diapason combinations.

But let's face it: Fats wasn't much interested in the variety of registration available on an organ. His forte was improvisations on themes and any combination which provided a good foundation for his distinctive doodlings was "in." Luckily, the richness of those variations overrides too critical a look at registration. What he does with a melody is what counts, not what stops he plays it on.

So, don't look for a lot of registration variety here; the improvisational ingenuity is the show.

The selections are middle-'20s pops. Most are forgotten now, although the Waller treatments tend to give them new life. Three are Waller originals, including his first "hit" written when he was 16, "Squeeze Me." Many of the titles reflect what used to be called "race music" — tunes written to appeal to the black community. These include "Eighteenth Street Strut," "Papa Betta Watch

Your Step," "Taint Nobody's Business If I Do," "Your Time Now," "Nobody But My Baby," "Do It Mr. So and So," "Clearing House Blues," "You Can't Do What My Last Man Did" and "Don't Try to Take My Lovin' Man Away." Familiar titles might include "I'm Comin' Virginia," "If I Could Be With You One Hour Tonight," "Laughin', Cryin' Blues" (Waller), "Midnight Blues" (Waller) and "Squeeze Me."

Some may complain about the lack of variety in style and tempo here, most tunes are played in the bouncing jazz mode associated with Waller. But we must take what Fats left us; he wasn't assembling a program when he made these piano rolls. At the time he probably needed the bucks. Yet he never compromised his artistry. If there is a sameness in the registration the interesting keyboard work compensates. His fillers, innovative intros, abrupt and offbeat endings, variations and general enthusiasm keep the toes tapping and, for some, the opportunity to analyze the Waller musical psyche, which was immense. Just the intense rhythm is enough to cause an aged reviewer to get up and pace the floor while listening. The only other composer who causes that phenomenon is Richard Wagner! Waller's rhythmic emphasis is contagious.

The release of this recording in the USA was undertaken by the Musical Heritage Society and we feel they couldn't have selected a better subject; Waller has never been accorded the credit due him as an organist. This disc will help, thanks to Ron Curtis who recognized the need.

Stereo recording is first rate. Kevin Daly's jacket notes are adequate and generally aimed toward the uninitiated but contain valuable Waller history.

Fats Waller died on a train taking him back to New York after having recorded music for the Armed Forces in Hollywood during World War 2. He was not even 50 years of age. Had he lived he would doubtless have produced more organ music in his distinctive style. Thanks, Ron Curtis, for making part of that hope a reality.

BILL VLASAK AT THE PARAMOUNT, played on the 4/42 Wurlitzer organ in the Paramount Music Hall, Indianapolis. No. WJV-101. Available postpaid from WJV Productions for \$9.75 (check or MO), Box 19746. Indianapolis, Indiana 46219.

A few issues back we reviewed a fine recording played by Donna Parker on this well-conceived instrument. Get set for another pleasant experience. Bill Vlasak is no stranger to this column. We've reviewed his work before but we feel that with this biscuit Bill has really come into his own realm as never before. But first, the organ.

Half of it was the 4/21 Wurlitzer installed originally in the Oakland California Paramount where it was recorded several times by that oriental favorite, Korla Pandit. It was claimed that it was the last "Publix No. 1" built by Wurlitzer. After several eatery engagements it found its way to Indianapolis

where it fell into the hands of Bob MacNeur, a young man with ideas about the commercial possibilities of a pipe organ installation. But Bob wanted a more elaborate instrument than just a plain Publix No. 1, an instrument designed by Jesse Crawford for a theatre chain in the late '20s. But it lacked a Posthorn; Crawford didn't feel that the local yokels could handle this raspy voice (obviously, Crawford had not experienced a Marr & Colton Kinura!). So MacNeur entrusted much of the instrument's enlargement to a gifted technician, John Ferguson, who had made a good name out West. In the end the organ doubled its number of voices — 42 ranks! Many other gifted people have been involved in the evolution of the organ (which employs pure Wurlitzer voices and parts), among them Larry MacPherson, Carlton Smith and Harry Helton (listed as "genius" on some jackets). And these names represent only part of the two-dozen craftsmen who justify Bill's jacket boast: "no finer instrument anywhere."

And he apparently set out to prove it. Bill Vlasak is in a class by himself. He's a veteran of many pizza emporium engagements. Yet there's not one whiff of frying lard or burnt crust in these selections. They are all concert quality performances. Likewise, his selection of tunes is miles away from the nearest pizzery.

Best of all — Bill Vlasak plays like a true theatre organist. That's not to say he sounds "old fashioned." Yet, he uses enough of the theatre musician's endings, modulations and between-phrase fillers to mark his music as the "real McCoy." He just has those qualities in his music which sound so right to the fan who remembers when most theatres featured an organist. Some of our younger crop of keyboard gymnasts could learn much about expression, registration and general approach to pops by hearing this recording, especially those who attempt to transform the pipe organ to something it was never intended to be. Here's a young man whose musical integrity complements the instrument. Let's examine the selections.

An energetic "Zip-a-Dee Doo Dah" (lots of subtle percussions) and a slow ballad "Sooner or Later," both from the movie *Song of the South*, point up the renewed interest in matters Disneyish, especially since the realization of Walt's dreams, Disney World and EPCOT Center in Orlando, Florida (all it lacks is a theatre organ, and we tried!). The ballad has the added attraction of the majestic Baldwin grand which was double-tracked onto the organ track. There's also a percussionist present.

"Puttin' on the Ritz" has long been a favorite of those who record standards on the theatre organ. The percussionist (Jack Gilroy) is back and adds to the lustre of the late '20s nightclub tune which will forever be associated with entertainer Harry Richman.

Bill Vlasak likes the percussions. He gilded the previous selection with tasteful plinks from the pitched percussers and this ancient (circa 1900) march provides a grand opportunity — "The Jolly Coppersmith." Bill has a field day with the old chestnut, one which



Bill Vlasak

only a true devotee of vintage theatre organ would attempt. He does fine.

Bill's *Naughty Marietta* potpourri conjures images of singers Nelson Eddy and Jeanette MacDonald, the pair who supplied the romance and fine vocalizing in so many MGM operetta movies of the '30s. Such treasures as "I'm Falling in Love With Someone," "Tramp, Tramp, Tramp," "Neath the Southern Moon," "Italian Street Song" and "Ah Sweet Mystery of Life" offer a treasury of Victor Herbert's best known and loved tunes. The one flaw in this presentation is the less than informative jacket notes. For example, none of the above titles is listed (hope we got them right; we winged them from memory). Registration and phrasing are appropriate for each selection, and there are echoes of the stylings of long ago theatre organists in the arrangements. Could Bill Vlasak be a reincarnation of several of the memorable ones?

Bill goes veddy, veddy British with "Rule Britannia," a tune written in 1740 which became an encouraging anthem to the people of Britain immediately and has remained a favorite ever since. Bill gives it a vintage untrem'd 1740 treatment (we won't use the word "baroque!") with the high solo Trumpet and contrapuntal effects associated with music of the period. The Trumpet en Chamade is heard (very posthorny), also the seven ranks of classical voices.

The Vlasak repertoire often reaches back to the '20s (and before) for tunes Bill never heard in their prime periods — but this reviewer often did, and the miracle is the accuracy, authenticity and sensitivity of his treatments of precious oldies. Such is the case of "Just Around the Corner," a 1926 tune linked to vaudevillian Ted Lewis, he of the battered top hat which often rolled down his arm and was caught just in time for the final note. On hearing Bill's rendition it would seem that he could have been Ted's accom-

panist — but we are dreaming a pleasant fantasy. Such is the Vlasak magic.

"Bill," from *Showboat*, is a lovely ballad which becomes even more entrancing in Bill's able hands. There are broad hints of Jesse Crawford styling and registration but no direct imitation. One just knows that somewhere along the line Bill has heard the Crawford version. As the most effective line in the jacket notes states, "Bill firmly believes the world revolves at 78 rpm." The Tibia and Vox often dominate and Bill occasionally uses "stings" on the pizzicato effect (or crescendo). He likes the high-pitched mixtures, too.

Leroy Anderson's "Buglers Holiday" is one of the best of that composer's lighthearted tunes, inspired by such fantasies as a "Waltzing Cat" and "The Typewriter" (with a real four-manual Royal plinking in the orchestra's percussion section.) This selection calls for precision triple-tonguing by three trumpeters. Although electronic organs are reputed to have a faster response than pipe action, this particular instrument is honed to provide action fast enough for triple-tongue effects. It's in fast tempo and the bugle calls are everywhere.

"I'll See You in C-U-B-A" was popular when Lucy's husband, Desi, was better known as a symbol of Cuba than a certain scruffy dictator today. So it sounds old-fashioned and very delightful. Again the Vlasak way with an oldie dominates. Bill is not averse to using re-iterating percussions (as some "modern" players are), and here we have a chorus featuring Marimba and later the Xylophone. The charms of these "woodpiles" is fully realized.

"Concerto No. 1" (Tchaikowsky) is limited to the popular excerpt from the concerto first brought to public notice as the theme of Orson Welles' Mercury Theatre radio series in the late '30s. Later, dance band leader Freddy Martin popularized the theme with his three-minute dance music version with Jack Fina on piano. It was a smash hit and may have helped inspire the no-merit song, "Everybody's Making Money but Tchaikowsky" during the period when all ASCAP music was banned from the networks (Tchaikowsky had long been in the public domain).

So much for ancient history. Bill's version starts "straight," that is, he recreates the symphonic orchestral voices on the organ, then, two Bills perform by the magic of double track recording. He's heard soloing on the concert grand piano accompanied by a very orchestral organ.

Then Bill switches to a chorus of the Freddy Martin pop version. He did so well playing pure Tchaikowsky the listener may feel short-changed by the contrast; we wish he had continued with the concerto. Yet, he performs the pop version faultlessly so we can't complain too much. He's gotta play "popular" and the end result is an effective closer.

The technical end of this recording is very high in quality. An excellent pickup (microphone positioning) coupled with a glassy-smooth surface and precision centering of that all-important hole, add up to a fine overall production. Highly recommended. □



BIOGRAPHICAL DICTIONARY OF THEATRE ORGANISTS

by Dr. John W. Landon

BLOOD, J. J.

Organist of the Queen Theatre, Muscatine, Iowa, in 1913.

BLUE, ALICE

Organist of the Palace Theatre in Hilo, Hawaii. Became organist of the Princess Theatre, Honolulu, Hawaii, following the tenure of Edwin Sawtelle, famous Hawaiian theatre organist of the 1920s and 1930s. She continued in this position until the early 1930s.

BLUM, FLORENCE (Miss)

Organist at the Strand Theatre in Schenectady, New York, in 1923, and of the Prospect Theatre, Flushing, Long Island, New York, in 1927. Organist on the Reid Circuit of theatres in New Jersey in 1928.

BLUNK, BILL (John William Blunk)

Professional organist in the northwestern United States. Played occasionally at the Paramount Theatre in Anderson, Indiana. Was organist of the Alexandria Roller Rink in Alexandria, Indiana. Leader of a dance combo which held a five-year engagement at a popular Oregon coast dinner club. Staff organist at Portland International Airport's famous Port West Dining Room. Teaches piano and organ at the Day Music Center in Portland, Oregon, and owns the giant 5/24 Marr & Colton theatre pipe organ that was originally installed in Loew's Rochester Theatre in Rochester, New York, in 1927.

BODE, FRANCES

Organist of the Clemmer Theatre in Spokane, Washington, in 1926.

BOCK, SYBIL

Radio organist who played the pipe organ theme for the "Lum and Abner" radio broadcast during a portion of the several years' successful run of this popular radio show.

BODYCOMBE, ANEURIN ("RED")

Perhaps the best known of the organists of Pittsburgh radio station KDKA. Born in the little village of Pontandawe, Wales, in 1899, Bodycombe's childhood was filled with the rich Welsh heritage of music and resulted in his decision to begin to study piano. After serving in the British Navy in World War I he emigrated to Wilkesburg, Pennsylvania,

where his grandfather lived. Upon his arrival in 1922 he found a job as an organist accompanying silent movies, but he didn't enjoy the work because the management wanted him to play popular music of the day. As a recent immigrant he didn't know many tunes popular in the United States.

Bodycombe turned toward the field of church music. In 1923 he became organist of the First Presbyterian Church in Wilkesburg and before long he accompanied some singers from the church on KDKA. It was his first taste of radio and he liked it. In 1929 he joined the KDKA music staff. He played the organ and piano and accompanied singers and groups. The next year he married a Wilkesburg girl, Esther Bothwell. In 1935 he became Musical Director for the station and for nearly 30 years he served the station in various capacities. In 1961 Bodycombe celebrated his twenty-fifth anniversary as organist and choir master of the First Presbyterian Church in Pittsburgh. During his years there his sacred compositions sold thousands upon thousands of copies. He retired from KDKA in 1964, spending the last few years with the sales department after the dropping of live shows in the mid-1950s.

One of the greatest honors Bodycombe ever received was an honorary Doctor of Music degree awarded him in 1954 by Waynesburg College. For several years he played a series of weekly broadcasts for the Dairyman's Cooperative Sales Association entitled, "DCSA Organ Melodies" and featuring Bill Nesbitt as announcer. These broadcasts demonstrated his sterling musicianship and were typical of the format of organ broadcasts across the country.

BOEHMER, LOUIS M.

Resident organist of the Hilliard Square Theatre in Cleveland, Ohio, in the mid-1920s (2/8 Kimball organ).

BOHR, RAY

Ray Bohr assumed the position of chief organist at Radio City Music Hall following the retirement of Dick Leibert. He served more years on the staff than anyone other than Leibert.

Bohr was born in Nyack, New York, November 2, 1919. He began studying piano at age six, and although he never took a degree

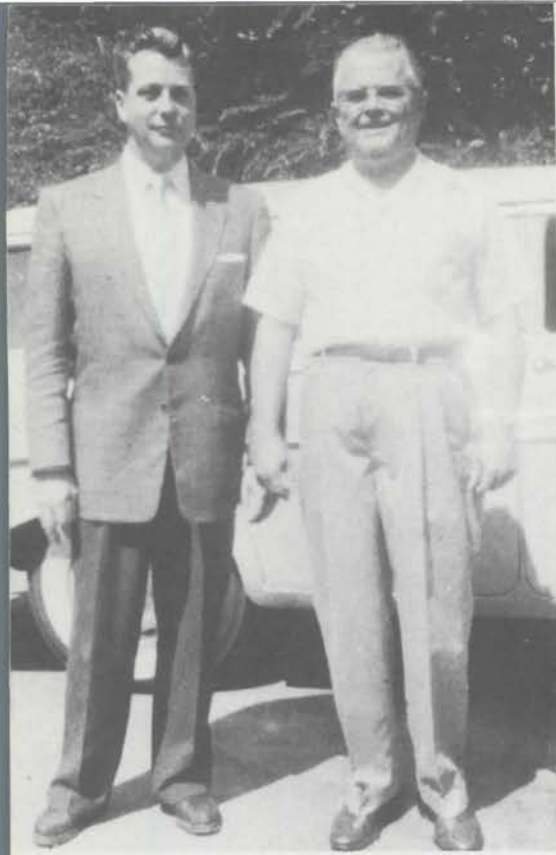

Ray Bohr (left) with Jesse Crawford, 1956.

in music, he was fortunate in having some excellent private teachers. Before World War II he studied with Robert Morse at St. John's Church in Greenwich Village, New York City. After the war he studied with Harold Friedell at Calvary Episcopal Church, New York City.

At age 14 Bohr took a job with M. A. Clark and Sons, who built and maintained pipe organs. He convinced the manager of the Rockland Theatre near his home that the 2/7 Wurlitzer in the theatre needed restoration. Bohr did most of the work himself, and once his ability as a musician became evident, the theatre manager hired him as regular organist.

Bohr also held church organ posts in Haverstraw and Pearl River, New York, before going into the army in World War II. The only time he touched an organ during the war years was when he played a memorial service at Iwo Jima for the late President Franklin D. Roosevelt.

After World War II Ray Bohr took a position as organ demonstrator for Wurlitzer and continued his classical organ studies. He became associate organist at Radio City Music Hall in 1947 while continuing to demonstrate for Wurlitzer. He began playing the pipe organ in the Rainbow Room at the top of the RCA Building in Rockefeller Center. During these years he also became organist for the television show "Bride and Groom," a post he was to hold for a year. He continued as associate organist at the Music Hall until he was advanced to chief organist in 1973, a position he held until the Music Hall closed and reorganized in 1978.

BOISCLAIRE, STEPHEN C.

Organist of the Leland Theatre in Albany, New York, in 1922. Organist of the Ritz The-

atre in Albany, New York, in 1927. Broadcast over WGY, Schenectady, in 1924.

BOLTON, ISABEL

Organist at the Windermere Theatre in East Cleveland, Ohio.

BOLTON, LAWRENCE

The Hippodrome Theatre in Dallas, Texas, had a 2/19 Pilcher. Bolton was organist of this theatre sometime in the decade before the 1920s. He also served as organist of an Episcopal church during the same period.

Owner George Walker opened the Ronile Theatre, located on Knox Street in North Dallas, Texas, early in 1920 using a Steinway Grand piano to accompany the picture. A 2/4 Hillgreen-Lane was installed shortly after the opening and Lawrence Bolton was engaged to play the organ. When he arrived to prepare for the opening the janitors started up their cleaning equipment which irritated him and he walked off the job, refusing to play there any further. Bolton was a regular organist of the Hope (Melba-Capri) Theatre on Elm Street in Dallas in the early- to mid-1920s. He did some radio broadcasting over Station WRR in Dallas. Bolton was a fine classical musician. He did play some radio broadcasts also over Station KRLD, but he never was a staff member at that station. He also taught piano and organ in the Dallas area. He died in the late 1960s.

BONAWITZ, KARL

Theatre organist in the Philadelphia area during the days of silent pictures. Played the Germantown Theatre in Philadelphia in 1924 and was vice president of the Theatre Organists' Society in Philadelphia that year. In mid-1925 he went to the Stanley Theatre on the Boardwalk in Atlantic City and in November of 1925 he was back in Philadelphia at the Stanley Theatre. In 1929 he was back at the Germantown Theatre in Philadelphia and broadcasting over Station WIP. He opened the Möller organ at the Metropolitan Theatre in Philadelphia.

Bonawitz died in August 1977.

BOND, EARLE

Organist of the Princess Theatre in Honolulu, Hawaii, with Virginia Smith, with whom he alternated for a time beginning in 1942 after organist Don George left to become musical director of USO shows during World War II. In 1942 organist John Demello came to the Princess Theatre. Bond remained for a time as his assistant.

BOND, WEBB

He was born November 30, 1913, at St. Johns, Michigan. His interest in music was only a hobby until after World War II when he studied music at Hope College at Holland, Michigan. He played the organ at a number of restaurants in the Grand Rapids-Muskegon area in the late 1940s. He was staff organist at the Majestic Theatre, Grand Rapids, from 1949 to 1952, where he played for such special functions as the Miss Michigan Pageant. About this time he met the manager of

the Michigan Theatre in Muskegon, who was instrumental in getting the organ renovated for the first time after many years of silence. He played at the Michigan Theatre as well as for the "Twilight Melodies" program on WKBZ, Muskegon. He played at a number of restaurants in Michigan before moving to Cincinnati in 1956. He has played many Cincinnati area restaurants, some special shows at the Paramount Theatre in Cincinnati, and in 1961 was organist for the Cincinnati Reds.

BOOMHOWER, CHARLES (C. D.)

Alternated with Robert Gordon Clarke as organist of the Capital Theatre in Detroit (three-manual Hillgreen-Lane) in 1925. In 1927 an advertisement showed him "At the Golden-Voiced Barton at Detroit's Oriental Theatre."

BOREA, CEAZAR

Organist of the Hope-Melba Theatre in Dallas, Texas, in the 1920s.

BORONE, VERA

Played the Grove Theatre in Chicago, Illinois, in 1928.

BORSA, THOMAS S.

Organist of the Rialto Theatre, New York City, in 1927.

BOSSERT, LUCILLE

Theatre organist in the Seattle, Washington, area in the 1920s. Played the Ridgmont Theatre in Seattle in 1926 and early 1927. Played the Woodland Theatre in Seattle beginning in mid-1927.

BOUCHARD, GEORGE ALBERT

Theatre organist in the Buffalo, New York, area. Played the Strand Theatre in Niagara Falls, New York, in 1922. In 1923 he played the Statler Hotel in Buffalo. In 1925 he played at Shea's Hippodrome Theatre in Buffalo, New York.

Ray Bohr at Radio City Music Hall, July 4, 1974.





Bill Blunk with his five-manual Marr & Colton console.

BOWEN, CHARLES

Assistant to Chester W. Walton at the American Theatre, Bellingham, Washington, in the early 1920s (Robert-Morton organ). He was later a teacher of classical piano and maintained a studio in the Fine Arts Building on Holly Street in Bellingham. Bowen was organist Gunnar Anderson's first music teacher.

BOYCE, JIMMY (James F.)

Boyce began piano study at age five and organ study at age 12. At 15 he was organist and choirmaster in a church and upon graduation from Peabody Conservatory in Baltimore he was granted a degree. While a teenager he was enraptured by the sound of the theatre organ by listening to Art Brown and Milton Slosser at Loew's Capital Theatre in Washington, D.C. In 1949 he was appointed organist at the America-On-Wheels Roller Skating Rink in Alexandria, Virginia, a cavernous building which resembles a National Guard Armory. It is a full city block long and 65 feet high.

Boyce believed that the theatre pipe organ was the answer to proper music in the arena. In 1956 with the approval of doubtful owners, a 2/6 Wurlitzer was installed. By 1960 a larger organ was desired and a 4/34 Wurlitzer organ originally in the Center Theatre in New York was purchased. It took several years before the new installation was playing, and the resulting installation more than adequately filled the arena with big sound, as all pipes, percussions and traps were installed without chambers. Boyce played his particular brand

of skating rink music for over 25 years.

He also played a 3/11 Barton at the Virginia Theatre, which was only a few blocks away from the roller rink. On Sundays he served as organist and choir director at St. Christopher's Church in Springfield, Virginia. The rest of his time was devoted to teaching, recording sessions and concert appearances. He performed for the American Theatre Organ Society's convention in 1972.

Boyce became one of a few theatre organists to appear in a motion picture. It was *Scorpio*, starring Burt Lancaster.

Boyce died December 31, 1980, at the age of 52 years.

BOYER, JAMES H.

Born September 10, 1909, in Elwood, Indiana. Boyer began learning piano at age seven. His first teacher was his mother. A year later he began taking from his mother's teacher, Claude Wright. Boyer's mother passed away in 1920 and his father remarried. His father was ordained to the ministry in the Christian Church (Disciples of Christ) in 1921. During the time that his father served a church in Bedford, Indiana, from 1923 to 1926 Boyer studied piano, organ and harmony with Roma Owen Martin. He also had two years of harmony in high school. He attended his senior year and graduated from the Martinsville, Indiana, High School, in 1927. That same year he studied piano at the Metropolitan School in Indianapolis (later merged with the Indiana College of Music to form the Jordan Conservatory) with artist-teacher Willard MacGregor. During those four years Boyer was church

organist first in Bedford, Indiana, and then in Martinsville, Indiana.

Boyer spent nine months' travel as a singing evangelist, ending up in Indianapolis, and it was here that he got his first real taste of theatre organ music and decided to become a theatre organist. He studied organ with Ruth Noller for nine months, well-known Indianapolis organist Dessa Byrd for two years, one year's study of piano with Roger Cushman, and seven and a half years of voice with B. F. Swarthout. In 1949 Boyer matriculated in Columbia University in New York City, and while there studied piano for four years with Harold Triggs.

Beginning March 1928 until September 1928 Boyer played for the Roy Bair Corporation Neighborhood Theatres. From September 1928 to December 1929 he played at the Circle Theatre and then the Indiana Theatre in Indianapolis. From January 1930 to May 1931 he was staff organist of Station WFBM (then a CBS affiliate). From May 1931 to May 1933 he was staff organist of the Indiana Broadcasting Corporation and Station WKBF (now station WIRE, Indianapolis), and Station WGBF in Evansville, Indiana. From May 1933 to July 1941 he broadcast over WIRE, and from January 1936 to July 1941 he was staff organist and vocalist with Shirley Brothers Morticians. From March of 1936 to April 1942 he organized and conducted his own band around the Hammond or-



ELECTRONIC ORGANS

Kit, or Custom Built

Kits for electronic or pipe organ renovation.

- Microprocessor-controlled, modular circuitry for ease of construction
- Authentic pipe organ voicing using active filter circuitry.
- Built-in capture system.
- Self-financing purchase plans.
- 7 basic models: 3 Church, 4 Theater, in 2-, 3-, and 4-manual sizes.

Attn: PIPE ORGAN BUILDERS

Incorporate, or replace, your stacks of switching relays with μ P-controlled latches. System will control up to 16,000 pipes and/or oscillators.

Write for quotation.

ARTISAN INSTRUMENTS, INC.

6450 N.E. 183
Seattle, WA 98155

PH: (206) 486-6555

TLX: 4998676 ARTSN



Alice Blue at the Palace Theatre, Hilo, Hawaii.
(Roger Angell photo)

gan. From July 1941 to September 1949 he was musical director of Station WISH, Indianapolis, and did solo club work with time out for World War II. September 1949 found Boyer at Columbia University in New York City. From March 1950 to May 1951 he played in a trio at the Shelton Hotel and broadcast over Station WOR, New York City, three nights weekly. From June 1951 until November 1951 he did solo club work on the organ at the House of McAray. From June of 1952 until July of 1959 he was organist of Budd's Restaurant in Jackson Heights, New York. During these working years, Boyer attended Columbia University and was graduated in 1955. In February 1959 he taught for the Baldwin Company in New York. In March 1959 he became organist and choir director of the Valley Stream, Long Island, Presbyterian Church and spent 12 years in that position. From January 1962 to November 1970 he taught in Hackensack, New Jersey, for a Baldwin-Gulbransen organ dealer. In November 1970 he retired and returned to Indiana. Boyer died in February of 1976. □

NUGGETS from the GOLDEN DAYS

Prospected
by
Lloyd
E.
Klos



February is here again, so we again devote Valentine's month to the lady organists who participated in the great era. References were *Melody (M)*, *Local Press (LP)*, and *Variety (V)*.

May, 1926 (M) While we are inclined to think of the photoplay musician's profession as being a typically American one, it is actually as cosmopolitan a profession as any, and

numbering among its ranks are musicians of every musically civilized country under the sun. The Strand Theatre at Seaside, Oregon, has for its organist Mrs. JEAN COCKS-DYCHE, who certainly reminds us in a most interesting way that photoplay theatre musicianship is international in its scope. She comes from the Antipodes. Her musical education was received in Australia, and a great part of her professional life has been spent in concert and musical work in Australia and New Zealand.

Mrs. Cocks-Dyche has some very interesting information on the music of the native Fijians, as well as that of Australia and New Zealand. Australia is a very musical country; we know that from the many successful tours booked for that country by internationally famous artists. Especially interesting is her account of the Christmas pantomimes produced during the holiday season in the theatres and concert halls of Sydney.

Many of the Australian theatres are so built that their roofs can be opened, and as Christmas in that country comes in the middle of their summertime, these pantomimes are often staged under the star-studded tropical skies with the Southern Cross as one of the spotlights. These pantomimes are of the old English variety and include "Mother Goose," "Jack, the Giant Killer," etc., staged in a very lavish and spectacular manner and running for weeks after the holidays.

Mrs. Cocks-Dyche is not only a capable organist; she also plays the piano and the violin, and has been very successful as a singer. She came to this country some time ago for a vaudeville tour, under the professional name of "Adi Viti," a native Fijian name meaning "Princess of Fiji."

This charming lady confesses to an overpowering fondness for the Pacific Ocean. During her residence in Sydney and also when she lived in New Zealand and on various other smaller islands of Australasia, the Pacific Ocean was always within visiting distance, and consequently when she located in the States as an organist, it was within sight and sound of this old friend.

Seaside is more a summer resort town than otherwise, and at first, Mrs. Cocks-Dyche was only there in the summer season, spending the winter in vaudeville and concert work. The Strand Theatre, however, has installed a new two-manual Robert-Morton unit organ, and during the past winter, Mrs. Cocks-Dyche has had charge of its console. She uses her vocal ability to advantage on the musical program of the theatre, presenting both concert numbers and semi-popular songs with slides. It is undoubtedly fortunate for Seaside and the Strand Theatre that they are located on the Pacific Ocean; otherwise, it is doubtful if the lady could have been induced to locate there.

October 30, 1926 (LP) WBZ in Springfield, Massachusetts, is presenting "The Home Folks Hour," a program of organ music by EDITH LANG, originating from the Boston City Club, starting at 6:30 p.m.

December 1927 (M) (By Henry Francis Parks) BASEL CRISTOL, organist, is one of

Chicago's most entertaining musicians. She comes of Irish stock, having been born in Dublin. As a pianist, she has appeared with the Chicago Symphony Orchestra, playing a concerto.

Her theatre organ experience has covered a period of over five years in some of the city's leading houses, including the Chicago, Uptown, Tivoli, Riviera, Central Park and Roosevelt theatres. She has appeared with great success at several of the Sunday morning recitals held at the Chicago Theatre and has, for the past five months, given the same sort of concert at the Tivoli on the south side. She is opposite Milton Charles on the Tivoli-Uptown rotation, usually going on the bill with Benny Kreuger, while Charles appears on the program with Ulderico Marcelli.

She is a capable improvisator and also presents slide novelties very effectively. But, aside from Mrs. Jesse Crawford of course, women organists do not seem to get as far as they should with the "firm" (as Balaban & Katz are familiarly known here), and Miss Cristol is no exception.

There is, of course, no reason why a woman cannot be as efficient an organist as a man. It is only a question of time until all producers recognize this; some of them do now, for that matter. But until that time comes, Miss Cristol and many other really fine women organists will not likely have the recognition and the opportunities their ability deserves.

1926-1930 Period (V) On the organ, the Crawfords sent in a great plug for *Hit the Deck*, now playing at the Belasco, a new musical hit with Vincent Youmans' compositions. Mrs. HELEN CRAWFORD was at the stage console and joined with her husband in playing "Hallelujah." How she can jazz on the organ! Mrs. Crawford should go in heavily on that. Her husband may have deferred in this, although it was an organ duet. Previously, he had played the show's theme song.

If the Crawfords ever played the organ such as the Paramount has, in Madison Square Gardens, for instance, and with the raggedy touch Mrs. Jesse can send across, it would put out of commission every dance hall in New York City. It's safe to say that such jazzing organ music as this would fill any place every night, if the organists could stand the strain. There is no better popular dance music.

GOLD DUST: The gals broadcasted too: 3/25 DOROTHY HAWLEY on KLX, Oakland, California . . . 7/25 JOHANNA GROSSE, WLW, Cincinnati . . . 10/25 PHYLLIS GRISWOLD, WOAW, Omaha . . . 11/25 JEAN WEINER, WPG, Atlantic City; HELEN WHEELER, WTIC, Hartford . . . 2/26 ESTHER NELSON, WTIC, Hartford . . . 8/26 MARY VOGT, WOO, Philadelphia . . . 9/26 ELAINE BAIR, WSUI, Iowa City . . . 11/26 MARGARET TIGHE, WBZ, Springfield, Massachusetts.

That should do it until next time when we will present another "pot luck" column with items from all over the lode.

So long, sourdoughs!
Jason & the Old Prospector □



1 Robert MacDonald backstage at Radio City Music Hall. Right hand on small door for gaining access to the right console.



2 MacDonald entering small room alongside organ niche.

Life At Radio City Music Hall Is Tough!

Photos by Dr. Edward J. Mullins



4 MacDonald squirming through the hole head first.



5 He made it! MacDonald performed this maneuver as many as 12 times a day on busy days.



3 Right console of the 4/58 Wurlitzer. Note hole on left side under key desk.



6 Robert MacDonald in a more dignified position at the 4/140 Schantz classical organ, Sacred Heart Roman Catholic Cathedral, Newark, New Jersey.



7



8

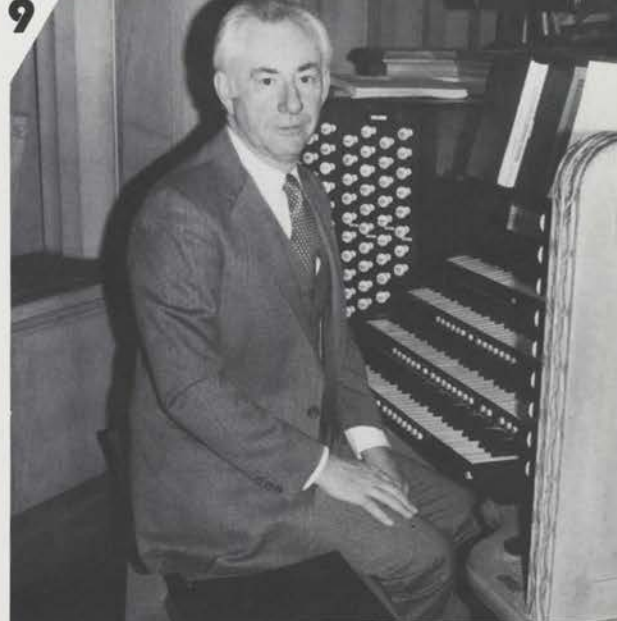

9

DAN BARTON'S TUNING PROCEDURE REVISITED

by John L. Little

"How to Tune an Organ" by Dan Barton in the July/August 1985 THEATRE ORGAN, originally published in *Posthorn* in April 1962, shows that organ builders/tuners of yesteryear must have been persons of great patience indeed. Electronics (organic and non-organic) has come a long way since the Wurlitzer heyday.

Today there are available the equivalent of precision electronic "tuning forks" for each of the notes in a rank of pipes or the strings in a piano. Each pipe or string can readily be tuned in unison with the sound from the electronic device and tuning is thus a snap.

To understand why Mr. Barton said "The imperfect scale was adopted in the 14th century and is now in universal use throughout the world," a few things should be noted:

1. In a chromatic scale of "equal temperament" every semitone increases in pitch by exactly the same percentage (just under 6%) from its lower neighbor.
2. In Mr. Barton's fascinating tuning procedure, each pipe to be tuned is compared either *up* seven semitones (perfect

fifth) or *down* five semitones (perfect fourth).

3. In equal temperament all octaves are pure and eight-note scales (do-re-mi — do) have the same impurity in all keys.
4. J. S. Bach (1685-1750) did much arranging of music for other composers, and he found it necessary to de-tune keyboard instruments slightly so that they would not need to be re-tuned every time the key signature changed. He used equal temperament.

Because, in a scale of equal temperament, there are 12 semitones in an octave, the percentage (or factor or ratio) between the pitch of adjacent pipes or strings, is what mathematicians call "the twelfth root of two," somewhat akin to the more familiar "square root of two" (1.41421 +) which multiplied by itself gives exactly two. The twelfth root of two is a number (1.059463 +) for which 12 successive multiplications of any number (or pitch) will exactly double that number (or pitch). For example, if we start with the number one (1) we will get the results shown at the left of Table 1.

TABLE 1

	Equal Temperament Ratio	Nearest Harmonic Ratio	Interval	Percent "Error"
1	1.00000	1/1 = 1.00000	Unison	None
2	1.05946	16/15 = 1.06667	Minor Second or semitone	.67% flat
3	1.12246	9/8 = 1.12500	Major Second or whole tone	.23% flat
4	1.18921	6/5 = 1.20000	Minor Third	.90% flat
5	1.25992	5/4 = 1.25000	Major Third	.79% sharp
6	1.33484	4/3 = 1.33333	Perfect Fourth	.11% sharp
7	1.41421	*	Tritone	
8	1.49831	3/2 = 1.50000	Perfect Fifth	.11% flat
9	1.58740	8/5 = 1.60000	Minor Sixth	.79% flat
10	1.68179	5/3 = 1.66667	Major Sixth	.91% sharp
11	1.78180	16/9 = 1.77778	Minor Seventh	.23% sharp
12	1.88775	15/8 = 1.87500	Major Seventh	.68% sharp
13	2.00000	2/1 = 2.00000	Octave	None

*Tritone is also called augmented fourth or diminished fifth. Ratios are 7/5, 64/45 or 45/32, and the sound is dissonant. Its equal temperament ratio is the square root of two.

Table 1 also shows the simple ratios, which, if voiced exactly, would make the music sound good for one key but not so good for other keys without re-tuning. The equal temperament ratios are the same for all keys, which is the ingenious feature of the scale of equal temperament.

It can be seen that the perfect fourth and perfect fifth have the smallest "error," which is why Mr. Barton chose these for his tuning procedure. Note that when the perfect fifth is used, the pipe being tuned is higher in pitch than the previously-tuned reference pipe and hence must be flatted about 1/9th of 1 percent (0.11%) of its pitch. If the perfect fourth were used to tune a higher-pitched pipe, then the pipe would need to be sharpened by that same amount. But, in Mr. Barton's procedure the perfect fourth is always used to tune a pipe down the scale, so those pipes also must be flatted.

Using Mr. Barton's scale as described in his noteworthy article observing the convention that A above middle C is 440 Hertz (called cps for cycles per second in older literature) we get Table 2. In tuning E to A, E becomes 330 Hertz. The amount to be flatted is 0.11% which is 0.363 Hertz, leaving E at 329.637 Hertz, in practical agreement with the value shown in Table 2.

TABLE 2

		Hertz
1	C	261.626
2	C# = Db	277.183
3	D	293.665
4	D# = Eb	311.127
5	E	329.628
6	F	349.228
7	F# = Gb	369.994
8	G	391.995
9	G# = Ab	415.305
10	A	440.000
11	A# = Bb	466.164
12	B	493.883
13	C	523.251

Other octaves are obtained by multiplying or dividing these values by 2, 4, 8, 16, etc. A table of values spanning ten octaves from 16 Hertz to 16,000 Hertz is shown on page 48 of the book by Olson (1).

References

1. *Music, Physics and Engineering*, by Harry F. Olson, Dover Publications, 2nd ed., 1967.
2. *The Physics of Music*, by Alexander Wood, University Paperbacks (London), Dover Publications (USA), 6th ed., 1962.
3. "A \$19 Music Interface (And Some Music Theory for Computer Nuts)," by Bill Struve, *Byte Magazine*, December, 1977, page 48. □

May we introduce . . . MELISSA AMBROSE



This charming young newcomer to the theatre organ scene is the 1985 winner of Motor City's Young Artist Competition and the runner-up in the National Competition. She amazed an impromptu audience at the Palmer House in Chicago when she sat down at an electronic console and entertained a group of conventioners with some creative arrangements that one would have expected from a much more seasoned performer.

Melissa is not without console experience, however, as she has been playing theatre organ since she was 12. Motor City first heard Melissa when she was 14 and performed at the Michigan Theatre in Ann Arbor for one of their Sunday "free" morning programs. Two years later she won the regional Yamaha Electone Competition and has subsequently played cameos at the Senate, Macomb, Royal Oak and Fox theatres and at the Punch and Judy in Grosse Pointe. She recently did a special program at the Senate during which she introduced an original composition entitled "Chimera," thus establishing her claim to creative as well as performing artistry. Ashley Miller also invited Melissa to play a cameo during his recent concert at the Redford.

Melissa is a protégée of Father Jim Miller and is, in addition, studying classical organ with Frederick Dehaven. She studies piano with Joyce Adelson at Oakland University. Father Miller is proud of Melissa's musical achievements and of her concert career. He feels that she has excelled in every aspect of her musical education.

A 1984 graduate of Royal Oak Dondero High School, Melissa received the Royal Oak Musical Merit Award as the outstanding musician in her high school and community. She is currently attending Oakland University where she is an honor student. She has been awarded the Lee Grekin Memorial Scholarship for outstanding musician and a scholarship from ITW through N.A. Woodworth where her father is employed.

Melissa lives with her parents, Mr. and Mrs. James Ambrose, and her two brothers, Jamie and Chris, at 2125 Dallas Street, Royal Oak, Michigan 48067.

Dorothy Van Steenkiste of Motor City Chapter says of Melissa, "She is a 'natural' with a winning personality. She loves the organ and loves performing. Her dream is to travel the world as an accomplished artist. With her determination, I am sure she will."

GRACE E. MCGINNIS □

Material for this article was furnished by
Dorothy Van Steenkiste.



33 Wood Street • Apt. 2104
Toronto, Ontario, Canada M4Y2P8
(416) 597-8803

Magazine Problems?

If you are not receiving your magazines, write to:

Douglas C. Fisk
P.O. Box 420490
Sacramento, California 95842

For back issues and binders, write to:

ATOS Back Issues & Binders
1393 Don Carlos Court
Chula Vista, California 92010

KEYBOARD TECHNIQUES



by Cheryl Seppala



SCALES

One of the first questions an organ teacher can expect from an aspiring new adult student is "You won't make me practice scales, chords and exercises, will you? I only want to play for my own enjoyment." If the teacher dare reply "Yes, you should learn these," he is likely to hear a ten-minute dissertation on how such busy-work was the cause of the student quitting piano lessons 50 years ago, never to play again. And besides, the organ is supposed to be easier — no elementary theory or harmony is essential. Right? WRONG!

First, practicing scales is an excellent way to loosen up our stiff fingers and improve our technique. Second, understanding what you are playing harmonically makes practicing easier and more interesting. Third, if you

learn a few simple mathematical-type formulas based on the major scale, you can figure out and play *any* chord in *any* key. This is so much more fulfilling than buying a \$1.98 chord chart.

But, before we leap into a study of chords, let's first make sure we understand the construction of the major scale, from which all chords are formed. A major scale is a series of eight notes, played in succession, following a particular order of whole and half steps. There are many other types of scales — minor, whole-tone and pentatonic to name a few useful ones. But for now, let's confine our interest to the major scale. Playing the C scale, comprised of all the white keys from C to C, is one of the first accomplishments of the begin-

ning keyboardist. Analyze the distances between the notes of the C scale: (W = Whole-Step, H = Half-Step)

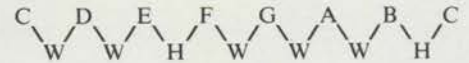

Notice the distance between any two notes is a whole-step, except between 3 and 4 and 7 and 8, where we find half-steps. All major scales conform to this pattern, no matter on which note they begin. That is the beauty of scale and chord harmony — there are no exceptions. If it works in one key, it must work in all 11 others.

To lay a strong foundation for a study of chords, you should learn all major scales. The following chart illustrates all the major scales with the correct fingering for each hand. Practice each scale up and down at least two octaves hands separately, then hands together. It is from the knowledge of these scales, that we will begin our study of chords in the next issue. □



BOOK REVIEW

ENCYCLOPEDIA OF THE AMERICAN THEATRE ORGAN: VOL. 1, by David L. Junchen. Published by Showcase Publications, P.O. Box 40165, Pasadena, California 91104. \$45.00 plus \$3.50 per copy for shipping (overseas and Canadian orders, \$5.00). California residents add 6-1/2% sales tax.

An encyclopedia, to most people, is a collection of facts, often dry and dusty, which one reads for needed information. Author Dave Junchen, however, has disarmed this stereotype with an encyclopedia of fascinating anecdotes, excerpts from personal correspondence, documents and photographs, and it is totally absorbing from cover to cover. It is a book for historians, for organists and for everyone with an interest in theatre organs.

In this volume (the first of three), Mr. Junchen has included 52 organ companies, from the Aeolian to the M. P. Möller, some of which are famous and others which are virtually unknown. He has documented even the smallest companies, whether it is with an ad or a picture of one of their organs. The opus lists, shipping lists, ads and photographs of the larger companies reflect the meticulous research that the author has undertaken. It will be of interest to many that the Barton story is, for the most part, told by Dan Barton, him-

MAJOR SCALES WITH FINGERING

RH 1 2 3 1 2 3 4 1	RH 1 2 3 4 1 2 3 1
C C D E F G A B C	F F G A B \flat C D E F
LH 5 4 3 2 1 3 2 1	LH 5 4 3 2 1 3 2 1
RH 1 2 3 1 2 3 4 1	RH 4 1 2 3 1 2 3 4
G G A B C D E F \sharp G	B \flat B \flat C D E \flat F G A B \flat
LH 5 4 3 2 1 3 2 1	LH 3 2 1 4 3 2 1 3
RH 1 2 3 1 2 3 4 1	RH 3 1 2 3 4 1 2 3
D D E F \sharp G A B C \sharp D	E \flat E \flat F G A \flat B \flat C D E \flat
LH 5 4 3 2 1 3 2 1	LH 3 2 1 4 3 2 1 3
RH 1 2 3 1 2 3 4 1	RH 3 4 1 2 3 1 2 3
A A B C \sharp D E F \sharp G \sharp A	A \flat A \flat B \flat C D \flat E \flat F G A \flat
LH 5 4 3 2 1 3 2 1	LH 3 2 1 4 3 2 1 3
RH 1 2 3 1 2 3 4 1	RH 2 3 1 2 3 4 1 2
E E F \sharp G \sharp A B C \sharp D \sharp E	D \flat D \flat E \flat F G \flat A \flat B \flat C D \flat
LH 5 4 3 2 1 3 2 1	LH 3 2 1 4 3 2 1 3
RH 1 2 3 1 2 3 4 1	RH 2 3 4 1 2 3 1 2
B B C \sharp D \sharp E F \sharp G \sharp A \sharp B	G \flat G \flat A \flat B \flat C \flat D \flat E \flat F G \flat
LH 4 3 2 1 4 3 2 1	LH 4 3 2 1 3 2 1 4

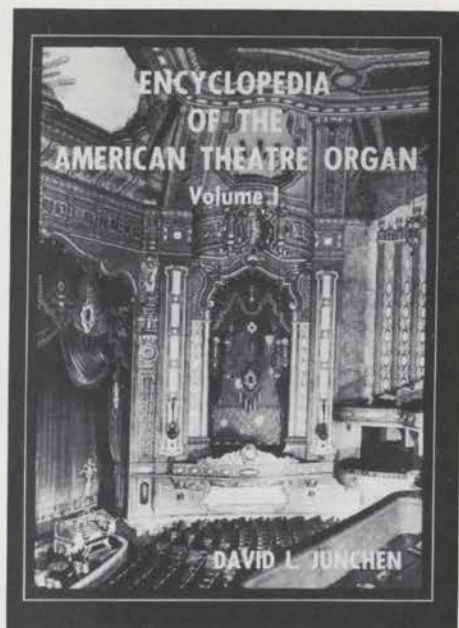

self, and is fascinating reading. It was fun to learn that when the author counted the ranks in the Chicago Stadium 6/62 Barton, he found that there are 51 ranks in this organ (see frontispiece). One wonders what surprises await us in the next volume!

The task of selecting and compiling such a vast amount of information might have overwhelmed some writers, but the conversational style and personal comments of Mr. Junchen would indicate that this has been a "labor of love." There are 23 pages alone containing information and photographs of the giant 7/452 Midmer-Losh organ in Atlantic City's Convention Hall. This is one of the most intriguing stories in the book. Perhaps the saddest note in the entire volume is the picture, on page 249, of the demolition of the Earle Theatre in Philadelphia in 1953.

This is a book which cannot be set aside after one or two readings. It needs to be kept handy for frequent reference. Professional organists will enjoy the stories of organs they have played during their concert tours; historians can check on the organs in their vicinities, and theatre organ lovers will enjoy encountering the men who made it all happen in the first half of this century. The only flaws in this edition are some unfortunate spelling errors and some "typos" which are minor distractions when weighed against the overall value of its content. Dave Junchen is to be commended for his dedication and devotion to the preservation of theatre organ history and lore, and we eagerly anticipate Volumes II and III. The book is worth every penny of the price!

PAUL J. QUARINO

Frank Olsen: Theatre Organ Virtuoso, by John Sanderson. Available from Sanmar Marketing, Box 567, Thorold, Ontario, Canada L2V 4W1. \$8.95, including postage and packing.

John Sanderson's memorial to organist Frank Olsen provides as much historical as biographical content. Mr. Olsen's career

spanned two continents and more than 50 years, and this period encompassed the advent of movie houses, silent films and talkies. The author presents some colorful descriptions of the early movie houses in England as well as some social commentary on the patrons and the times. He says:

"Working class people whose lives were momentarily alleviated by the beer-drinking camaraderie in public houses, naturally thought of them as picture houses. Their children, often filthy ragged and sometimes without footwear, even in the nineteen-thirties, queued excitedly every Saturday outside what they chummily called flea-pits. Did they know that flea-circuses procured much of their stock from slumdom's stinking picture palaces?" (pages 7-8).

Frank Olsen's theatre organ career began in 1926 when he was just shy of 18 years; he was the youngest "Orchestral and Solo Organist for the City Picture House in Peterborough." (p.15) On New Year's Day, 1929, he gave his first solo recital on the Jardine Orchestral Organ in St. George's Hall in York. The place where he gained most fame, however, was the Picture Palace in Glasgow where he played a Wurlitzer Model F. In 1967, Frank accepted a position at the Central United Church in Port Colborne, Ontario, where:

"To his surprise, he found the theatre organ more alive in North America than in Europe. The instrument, although no longer played in the majority of North American cinemas, was nourished by enthusiastic fans who grouped themselves into *Theatre Organ Societies*." (p.29).

His remaining years as a performer and teacher were spent in Canada, but he did return to England for a final concert at the Odeon Cinema where he died at the console on September 4, 1983.

Although this is a small book (31 pages), it is large in its devotion to, and admiration of, the man it honors. Anyone who has an interest in history or in theatre organ will find it most interesting.

GRACE E. MCGINNIS

The re-opening of the South Bank Wurlitzer, A souvenir Programme and Brochure, compiled by Victor Patterson. Published by The Cinema Organ Society. Available from COS Sales, 23 Aveling Park Road, London E17 4NS, England. \$6.00, airmail postage included.

The South Bank Wurlitzer, located in Edric Hall of the Polytechnic of the South Bank, in the London Borough of Southwark, was re-opened on November 8, 1985, with a program featuring four British organists. The organ is the 4/21 instrument originally installed in The Trocadero Cinema, Elephant and Castle, London.

This booklet begins with biographies and photos of the four artists, together with lists of the musical selections each played. Following that is a brief story by Tony Moss about The Trocadero Cinema, with an exterior and an interior view of the theatre. Next, Wayne Ivany describes, with text and six photos, the

Trocadero Wurlitzer and the artists who played it. Compiler Victor Patterson describes the removal, reinstallation and opening recital at Edric Hall. This is followed by "Restoration, Re-opening and Future," by David Lowe, and Victor Patterson completes the booklet with some technical information and the specification of the organ.

Well-written text and 26 photos make this booklet very interesting reading, and we shall treasure our review copy.

Farewell Mr. Blackpool, A souvenir tribute to Reginald Dixon MBE, by Tony Bernard Smith. Published by The Cinema Organ Society. Available from COS Sales, 23 Aveling Park Road, London E17 4NS, England. \$3.00, including airmail postage.

This booklet was written over a weekend and rushed into print to have it ready for the Dixon Memorial Concert at the Tower Ballroom on July 14, 1985. But the rush is nowhere apparent; it is a loving tribute to the world-famous organist, beautifully written and beautifully produced. A copy should be in the library of every dedicated theatre organ buff.

In these few pages the author has given us biographical information, facts about the Wurlitzers in the Tower Ballroom, background on some of Dixon's recordings, and "The Dixon sound," a short discussion of his musicianship and playing technique. The booklet contains 19 photographs in addition to the portrait on the cover. □

**NO ROOM FOR PIPES?
BUILD A DEVTRONIX
FOR THAT PIPE ORGAN SOUND**



**5 Models To Choose From
(3 & 4 manual consoles)**

Brochure \$2.00 Product Catalog \$2.00
Demo Cassette \$4.95, played by
EVERETT NOURSE

**REVERBERATION
FOR ORGANS**

Solid state with controls for reverberation and room size.

EVERY ORGAN SHOULD OWN ONE.

Send for free flyer -



**6101 WAREHOUSE WAY, DEPT. 30
SACRAMENTO, CALIF. 95826
(916) 381-6203**

The Theatre Organ . . . Wherein Lies Its Future?

by John Ledwon

The theatre organ movement of today is suffering from, at best, a static interest level and, at worst, a gradual decline of interest. What can be done to increase interest, particularly with the younger segment of our population? I offer the following suggestions, based on my experience in working with persons 16 to 22 years of age in a musical environment for the past ten years, both as a professional musician and as an educator.

We of the theatre organ world need to involve the young in order that the movement stay alive. We must involve large numbers of people with diverse talents and interests if we expect to see large scale growth. ATOS and similar groups must examine their goals closely to see if they are current and if they are on a musical track that appeals to a large portion of the general population. The theatre organ must be made to appeal to a much larger potential audience if it is to survive.

The theatre organ has proved that it can excite and enamor audiences of the '70s and '80s; just look at the crowds and their reactions and enthusiasm at pizza parlors. Unfortunately, this ray of hope is diminishing. Why? Possibly because the pizza parlor organist either couldn't or wouldn't present music from today's current repertoire, or perhaps the theatre organ couldn't perform current pop music credibly. It's okay to delight the six-to 12-year-olds with tinkling bells and snappy drums and help the senior population relive happier moments with music they grew up with, but what about the 16-to 35-year-old group? They are the future audience, and their music has been largely ignored.

Here we have what I consider to be the focus of the problem of generating greater interest in theatre organ — the inability or unwillingness of the majority of today's theatre organ artists to play current pop music and the fact that the theatre organ, in its current configuration, cannot compete musically with today's "sound" without the assistance of other instruments. Let me address each of these. First, the artist's ability or willingness to play current pop music. Let's look at willingness first. Presently, much emphasis is placed on keeping the senior population happy, mainly because they are the principle sup-

port group providing funds for the artists and related business interests. If audiences demand music from the '20s, '30s or '40s they get it, mainly because if you deprive them of it they will not attend concerts. So here we have a "Catch 22" situation: older audiences pay the bills and demand music from a bygone era; younger audiences stumble onto a theatre organ concert out of curiosity or whatever, are turned off by the music presented and never return. Now, is it only the musical selections presented that turns off this younger audience, or are other factors involved?

Current pop music is quite complicated rhythmically and is largely vocal in nature. Admittedly much current pop music will not transfer credibly. By credibly I mean in a manner which captures the original mood and drive of a selection of music. Music that will not transfer must not be performed, as it will probably turn out stilted and strange, or worse, comedic. And that is a great way to turn off a younger audience. Current pop music that will transfer well will probably require assistance from other musical sources. The addition of a rhythm section (percussion and electric bass) and an accent section (brass or a synthesizer) will do wonders to the overall sound. Many theatre organ purists will fight tooth and nail this practice of adding other instruments to their beloved theatre organ. However, for the theatre organ to survive in the '80s and beyond it must be done. How many solo musical instrumentalists can you name today (other than vocalists)? Not many, I think. Today's successful musical presentations are cooperative efforts; a single solo instrument just won't make it in today's musical world. When I speak of augmenting the theatre organ with other instruments I don't mean the "Big Band" sound. That era has also passed. I speak of augmentation with electric bass (artists, get off the 16' extensions . . . they're murder in today's modern sound), percussion (not the toy counter but a real live percussionist), brass (not the Post Horn but good brass musicians or a good *professional studio* synthesizer). This "re-creating" the modern sound is why so many good theatre organ artists shy away from current pop music. Most of it cannot be re-created

credibly on a solo theatre organ, and many artists are reluctant to engage other musician's assistance at concerts because of the added expense and cries of outrage from the purists who feel adding anything to the theatre organ is a desecration of the art.

Which brings us to you, the audience. In most cases, the senior audience. What can you do to help the situation? Simply accept change, for without change there can be no future . . . for anything. We live in the '80s; accept that. Sure, things were great in the '20s, '30s and '40s, but would you trade in all the technological advances of today for those of past decades? Probably not. The same goes for today's musical world. Music is an art form in a constant state of flux; stifle this and it dies. The theatre organ movement is static and living in the past; either it moves forward toward the present or it is doomed to gradual extinction. Today's audiences must compromise some of their views and tastes and allow a good portion of a concert to be music of today registered for today. And if that means adding other instruments, so be it. Enjoy the added variety, the new musical experiences. There is a whole new world out there musically, and I'm *not* talking of Acid Rock, Hard Rock, Punk or New Wave, just good contemporary music that sounds great on a theatre organ (with a little assistance from other instruments).

Today's audiences hold the key to the future of the theatre organ. Change your tastes and attitudes and the movement will expand because the artists will introduce new ideas and styles; remain static and you've killed the instrument you profess to love. Expand your musical horizons! Listen to some of the milder contemporary composers. Not everything they write is good, but then, neither were the composers of the past perfect. The milder composers may not be the principle music of the young, but they listen to it and most of them enjoy it. Composers like Andrew Lloyd Webber (who constantly uses nostalgia in his compositions), John Williams, Neil Diamond, Barbra Streisand, Bruce Springsteen and a host of others all have something important to say musically and we need to listen. Also, go see a contemporary motion picture;

examine the tastes of the young. Accept and embrace what you can and try to tolerate the rest. Remember, you were young once and someone most likely had to tolerate your tastes. (I wonder what people born in the 1880s or 1890s had to say about music of the 1920s and '30s.) Go see *Back To The Future*, it's loaded with '50s nostalgia, or see Ron Howard's *Cocoon*. They are both great flicks and if they make you smile and see today's entertainment in a slightly different light they've served their purpose. Also, demand that today's concert artists play music from today. When you find an artist who embraces modern music and styles, don't run away . . .

SPREAD THE WORD! Take your grandson or granddaughter to the concert. Expose today's youth to their music performed on a theatre organ. Don't take them to a concert of dated music. I can practically guarantee they won't like it and won't go again. To involve today's young people you must meet them on their terms and give them what they want to hear or they will go elsewhere. There is too much going on musically that appeals to them for them to take the time to understand that which they think they don't like. We must educate them from where they are to where we want them, not the other way around.

One final important point and I'll get off my soapbox. Those of you who are artists or producers of theatre organ concerts must consider yourselves part of the entertainment industry. In order to compete in today's competitive entertainment business, artists and producers must learn to entertain through more than just the auditory portion of the brain. Spectacular lighting, backdrops, staging variety and perhaps positioning the console in such a manner that the artist's back is not always toward the audience (the weakest of all staging positions) must be considered.

How many of you have noticed that I have consistently used the word "artist," rather than "organist"? Why? First, like it or not, the term "organist" or "organ concert" turns off the majority of people today. So, why use it? Find some other way of saying the same thing. Who knows, you might pick up several unsuspecting audience members who might otherwise not have attended the concert. Secondly, for an artist to appeal to the area of potential audience that is going to be needed in order that the theatre organ movement may survive and expand, he or she will need to be more than an organist. Superior musicianship, knowledge of orchestration, versatility in staging techniques and the ability to communicate with the audience in a unique and entertaining style will all have to be shown by the artist if we are to move forward.

Certainly, all of this is going to take time, effort, money and, above all, creativity. But if we don't aim for the top we certainly can't ever come anywhere near it. New blood must be infused into the movement in order for it to survive. Emphasizing contemporary music performed in a contemporary style and staged with contemporary theatrical techniques is a possible solution. The challenge is there; are we capable, both creatively and innovatively, to meet it? To surmount it? □

JANUARY/FEBRUARY 1986

PIPES & Personalities

15th Annual Mid-Tennessee Organ Bash a Hit

Cumberland Caverns, Tennessee — Roy Davis' Cave Crawl and Organ Bash was again well-attended on November 2. The Chattanooga ATOS Chapter hosted the first stop at the Tivoli Theatre, where manager Clyde Hawkins made the three-manual Wurlitzer available to the tourists. Next stop was the Henry McKinney residence in Chattanooga with its 2/6 Wurlitzer. A new addition to the safari was lunch aboard a moving steam-powered train at the Tennessee Valley Railroad Museum. \$8.75 bought a train ride, a BBQ sandwich, chips and a drink. The annual trek is accomplished by auto and Roy Davis provides a detailed description in his brochure for the benefit of drivers. On to the Allee residence in Manchester, but unfortunately Roy didn't include data on the size of the Allee organ, but describes it as a four-manual Estey. Burt and Ann Allee also have an Ampico grand piano, an orchestrion and jukebox. So the time spent there was lively.

Next, back to McMinnville and the Roy Davis warehouse. For the uninitiated, Roy is a dealer in pipe organs and parts; he maintains a generous supply of goodies to tickle the appetites of collectors. He has three three-manual Wurlitzers set up in the warehouse but doesn't say whether they are in playing condition, although we suspect that at least one is. To quote him, there are "old theatre furnishings, theatre antiques, toys, trivia and junk — enough to confound, confuse and disgust you! Bring your U-Haul trucks!"

At 7:00 p.m. there was the annual banquet in the cave, followed by a tour of the caverns.

There can be little doubt that Roy Davis is upholding the best interests of the theatre organ hobby — even if he is "in the business."

Calcaterra a Hit With Kids

Nearly 1000 students in Hudson, Wisconsin, were entertained by Rob Calcaterra in several sessions at Phipps Center for the Arts. He played the Wurlitzer formerly installed in the studio of radio station KSTP, St. Paul. In addition to playing popular tunes and silent movie music, he talked about music and his experiences as an organist. Closing the series was a night concert for the public.

In October Rob demonstrated another facet of his musical talent by conducting an or-

chestral concert at Symphony Hall in New York. The program featured two world premieres: a piano concerto by Swiss composer Ruth Schmid-Gagnebin entitled "An American Rhapsody"; and "Spielmusik" by Paul Hindemith. Rob has also been busy composing a variety of musical works.

Oakland Paramount Installs Sennheiser Hearing-Impaired System

The Paramount Theatre has installed a Sennheiser hearing-impaired system for public use. Listening receivers for hearing-impaired patrons, including those who utilize hearing aids, are available free of charge.

One of the main benefits of the Sennheiser system is that it only picks up sound originating on the stage and not noise around the patron using the system, according to Peter J. Botto, General Manager. Emitters mounted on the walls of the auditorium send infrared light containing an audio signal throughout the theatre.

There are two different receivers which can be used with the Sennheiser system. Lightweight earphones can be worn under the chin, attaching comfortably to the ears much like headphones one uses in an airplane, or a person with a more profound hearing loss who relies on a hearing aid with high amplification may choose the second receiver, which consists of a small induction loop which hooks behind the ear right next to the wearer's regular hearing aid. The audio signal is fed directly to the induction loop; instead of going through earphones. This over-the-ear device also comes with a small, lightweight energy pack which the user can clip to his or her belt,

Rob Calcaterra conducting an orchestral concert in Symphony Hall, New York.



THEATRE ORGAN

pocket or purse.

In the San Francisco Bay Area many major facilities have installed the Sennheiser hearing-impaired system: the Curran, Geary, Golden Gate and Orpheum Theatres, Berkeley Repertory Theatre and the War Memorial Opera House. Sennheiser systems are soon to be installed in Davies Symphony Hall and Herbst Hall. Individuals who regularly attend theatre and music events can purchase their own receiving units from a hearing-aid dealer for use in theatres utilizing the Sennheiser system.

Three people who devoted a great deal of time and effort, largely behind the scenes, to organizing and handling details of the "Pipes Alive in '85" Chicago convention were not properly recognized in THEATRE ORGAN. For this oversight, the staff members extend their sincere apologies. Bill Rieger was Vice Chairman of the CATOE Convention Committee, Charlotte Rieger handled the Record & Souvenir Shop, and Beverly Barton was Registrar. That they handled their jobs well was evident to all who attended the convention.

When Rochester's Eastman Theatre was renovated in the early '70s, the 4/155 Austin organ was removed, much of it consigned to the scrap heap, though the echo organ still remains in its chamber above the auditorium. The console, which had been in storage, went elsewhere. Now, we have specific news of its ultimate destination. According to New Jersey organist Warren Clark, the ex-Eastman console is in the Cathedral of Sts. Peter & Paul in Philadelphia. It has been modified, with numerous stop tabs removed.

Bert Buhman's annual organ concert extravaganza for the School of the Ozarks' Scholarship Fund came off very well on October 13. General opinion seemed to be that the event was the best of all the programs thus

Charlotte and Bill Rieger.



far. Bert and his "twin" practiced at least six hours a day to get things the way he wanted them. The PA system in the Nettie Jones Theatre was completely reworked, and this time, the sequences of 3/15 Wurlitzer and piano, and organ, piano and orchestra turned out excellently. The theatre pipe organ continues to be alive and well at Point Lookout, Missouri.

The Organ Literature foundation has recently issued its "Catalogue T," which lists substantial additions to its vast stock of organ books, recordings and sheet music. Of the 323 theatre organ recordings, 68 are newly listed. Readers may obtain a copy of the catalog for \$1.00 or four International Reply Coupons (for sea-mail, eight for airmail), which is refundable with the first order. The Organ Literature Foundation, 45 Norfolk Road, Braintree, Massachusetts 02184.

Mercia Publications of England has recently published a hardback book titled *Odeon*, which is a photographic survey of the 145 streamlined Odeon cinemas specifically built for the original Odeon circuit. Mercia also offers a series of illustrated booklets covering many of the "picture palaces" in Great Britain. Detailed information may be obtained from Hugh Sykes, 78 Hawthorne Road, Kingstanding, Birmingham B44 8QP, England.

"I Remember Mama" Is Remembered

The Museum of Broadcasting in New York City sponsored an exhibition honoring the classic domestic comedy series "Mama," which ran on CBS-TV from July 1, 1949, to March 17, 1957. What is interesting to theatre organ buffs was that Billy Nalle played the music for every episode of the series. The instruments used were a CBS-TV studio Hammond with special speakers and a reverberation chamber, and a celeste, with the occasional addition of a piano. According to Rob-

(Chuck Wlodarczyk photo)

Beverly Barton.



ert Batscha, president of the museum, "I Remember Mama" was apparently the only nighttime TV series to use organ music.

Vancouver Orpheum Scene of Tribute

Mayor Mike Harcourt of Vancouver, B.C., proclaimed October 30, 1985, as "Ivan Ackery Day." Who is Ivan Ackery, and why the special day? Well, 50 years earlier, he took over management of Vancouver's Orpheum Theatre, the flagship of the Famous Players chain. He continued to manage it for 35 years.

In the golden age of moviegoing, an enchanted evening at a picture palace meant double features, extra added attractions, stage shows, contests and prizes, and the sound of a theatre pipe organ. And Ivan Ackery made it all happen for the people of Vancouver.

Theatre managers were expected to promote the films on very limited budgets, and to provide incentive the movie industry set up competitions and large cash prizes. With his love of show business and flair for publicity, Ivan won more prizes and awards than any other manager. Competing against more than 19,000 others in the English-speaking world, he twice won the Martin J. Quigley Award, known as the theatre managers' "Oscar." There was virtually no business or organization in Vancouver that he did not involve in promoting a movie. Something special was always happening at the Orpheum, attracting a million people a year, who were made to feel special just being there by the friendly staff and warm atmosphere.

A company rule required Ivan Ackery to retire in 1969 at age 70, but he retained his interest in the Orpheum and participated in the "Save the Orpheum" campaign in 1974-75.

The Fiftieth Anniversary Tribute program included Dal Richards and His Band, the Royal New Westminster Regiment, two pipers, a magic presentation and a ballet number, followed after intermission by an organ solo played by Frank Mankin on the 3/13 Wurlitzer. He then accompanied the silent film *Son of the Sheik*, which starred Rudolph Valentino and Vilma Banky.

ATOS member William G. Hale, who pro-

(Chuck Wlodarczyk photo)



Manager Toni McSwain and organist Paul Quarino share a laugh before the show at the Egyptian Theatre in Coos Bay, Oregon.



Paul Quarino and former owner Stan McSwain stand to show the height of the birthday cake at the Egyptian's sixtieth anniversary party.

vided the information for this article, is a member of the tuning and maintenance crew for the Orpheum Wurlitzer.

The Egyptian Is 60

The Egyptian Theatre in Coos Bay, Oregon, celebrated its sixtieth anniversary with three nights of vaudeville and silent films on November 17, 18, 19. The Egyptian is one of six theatres on the West Coast that still houses its original theatre pipe organ in playing condition, this one a magnificent Wurlitzer Hope-Jones Unit Orchestra Organ installed in 1925. Portland organist Paul Quarino did console honors for the three nights of nostalgia.

Paul opened each show with a program of music from old movies and then accompanied a newsreel from the 1920s, a *Felix The Cat* cartoon and *The Playhouse*, starring Buster Keaton. The light and lively vaudeville shows featured seven acts including belly-dancing, comedy, singing and magic. Eighty-year-old Doris Curtis, who had been in the audience the night the theatre opened in 1925, sang "Some of These Days" and "Last of The Red-Hot Mamas." Toni McSwain, manager of the Egyptian, masterminded this extravaganza, and Bob Diedrich served as producer/director. Toni has been associated with this theatre since she was a child and her father owned it. She was, however, as surprised as the stage crew to find five original hand-painted vaudeville backdrops hanging in the flyloft in almost perfect condition. These were used as background for the vaudeville acts.

The theatre, which is now owned by Luxury Theatres, still has its original hand-painted Egyptian motif throughout the auditorium, and the lobby is flanked by two enormous seated colossi. The organ speaks from behind plaster slaves playing Egyptian harps, and 1925 melds into 1985 only in the modern pro-

jection system and the computerized ticket booth.

This celebration involved many individuals in the community, and the audience response was most enthusiastic. The residents of Coos Bay are hoping that Toni will make vaudeville and silent films a regular feature at the Egyp-

tian.

Toni will be happy to show the theatre and the Wurlitzer to any ATOS members who may be traveling along the Oregon Coast. She can be reached by calling the theatre at 503/267-6115.

GRACE E. MCGINNIS



Closing Chord



Squire Haskin, Buffalo, New York's best-known organist and pianist with the city's Philharmonic Orchestra, was murdered in his room near Kleinhans Music Hall on October 11. There was no sign of forced entry or robbery. A graduate of the Eastman School of Music, he was featured in the early years of radio on Rochester's WHAM.

Well known British theatre organ enthusiast **Reginald G. Mander** died October 12, 1985, of cancer. He was 64 years of age. He became increasingly ill during the year, and spent his last three weeks in St. Gemma's Hospice, Leeds. Early in the year, he took early retirement from work to cope with the situation, which also involved caring for his 91-year-old father, his invalid mother having died many years ago. In recent years Reg had been less able to participate in organ activities, but up to July he performed his duties at Ossett Town Hall, where he introduced the public concerts and operated the stage lighting, among other things.

Born at Peterborough, his parents moved to Leicester before he was two, and then to Chester, until settling in Leeds in 1932. Through hearing broadcasts and seeing some organs during cinema visits, Reg was already a cinema organ fan and had begun to collect records. He started work as an apprentice in the electrical trade, and during the war he served in the Royal Air Force, part of the time

in Australia, where he saw many organs and met several organists, as well as obtaining records which he brought home with him. Returning to his former work, he was soon to be-

Reg Mander, seated at the 3/8 hybrid organ in his home. Note the tone opening directly above the console. Photo taken in the mid-1960s.



come involved in office duties, which continued up to his retirement.

After joining the Theatre Organ Club in 1949, he attended organ events in all parts of the country, but he particularly looked forward to the annual Blackpool Rallies and enjoyed a personal friendship with Horace Finch. In 1948, the family had moved to Rothwell, near Leeds, and bi-monthly Saturday social evenings for the T.O.C. were held at his home, with record sessions and music on the pipe organ which was under construction. The start of this instrument was a two-manual-and-pedal reed organ which Reg had received when he was 21, and to which he added a set of Stopped Flute pipes and some percussions.

Upon meeting Frank Hare, consideration was given to something more substantial, first with a mixture of pipes and Aeolian reed chests played from a detached console, but gradually an entirely pipe organ with electro-pneumatic action was constructed to Frank's specification. The two of them spent thousands of hours over several years building the organ which resulted. In spite of low-pressure pipework, it sounded truly "theatrical," and included ex-theatre organ tonal percussions, traps, relays, manuals and stopkey units. It was arranged some years ago that in the event of Reg's death, the organ would be donated to the Lancastrian Theatre Organ Trust, and although changed circumstances will prevent the organ being used for the purpose originally in mind, the Trust is now arranging for its reinstallation in Lancashire.

Reg's vast collection of 78 rpm organ records from various parts of the world, together with his research into the subject, enabled him to co-compile (with Dr. Mel Doner) "Theatre Organ Discs of the World," which was published in TIBIA and THEATRE ORGAN in issues from 1956 to 1960.

His liking for dance and popular numbers of the '20s and '30s on records led to an interest in player piano rolls of the same period. He acquired a pianola and built up a large collection of rolls, and constructed a perforator machine to copy rolls for those who could not otherwise obtain them. Later, by taking extracts from existing rolls, he produced selections of music by composers, or with subjects in common. He even made a roll player for attachment to the organ, adding the extra perforations required for the pedal section and for the operation of the stopkeys and the swell pedals. His most recent publications have been listings of piano rolls, and he was sifting through new information while in the hospital, within a fortnight of his death. His reading matter included the magazines on his other "love," trams. Again, his knowledge of tramway systems was extensive, and in the old days he visited many of the places where they operated, as well as being an active member of the local society.

In the present day organ world, Reg is probably best known for his involvement with the organ at Ossett Town Hall. A committee member of the Northern Theatre Organ Trust from its inception, he participated in the ini-

tial negotiations with Ossett Corporation, subsequently becoming a member of the team which installed the organ over a 5-1/2-year period and has since maintained it. He assisted at the concerts over the past 15 years, becoming N.T.O.T. Vice-Chairman in 1975,

and the Chairman since 1980. On several occasions he talked about the Ossett instrument, about his own organ, and about general organ subjects on BBC Radios Leeds and Manchester.

FRANK HARE □

Letters to the Editors

Opinions expressed in this column are those of the correspondents, and do not necessarily reflect the opinions of the editors or the policies of ATOS or THEATRE ORGAN.

Letters concerning all aspects of the theatre organ hobby are welcome. Unless clearly marked "not for publication" letters may be published in whole or in part.

Address: Editor, THEATRE ORGAN
3448 Cowper Court
Palo Alto, CA 94306

Dear Bob:

I read the last issue of THEATRE ORGAN which covered the 1985 convention in Chicago. I was surprised to see the collective review, but while I might have not been so direct, I feel the review, as printed, pretty well covered the convention performances.

I have just returned home from the Phoenix Festival, and it is sad that only 300 could be accommodated. Congratulations are in order to Valley of The Sun Chapter!

Sincerely,
Harry Heth
Houston, Texas

Dear Bob:

This is not primarily a theatre organ question, but perhaps someone who does a lot of organ recording can give me an answer.

I have many old reel-to-reel tapes that, despite great care, seem to be drying out. They become very noisy passing through the playback heads, and sometimes distort the sound.

Years ago there used to be a lubricant for the tape but I can no longer find any, though I have written to 3M, Tandy Corp. and others.

Can anyone tell me what to do about this condition?

Thank you,
Bob Longfield
371 Tahiti Street
Morro Bay, California 93442

Dear Editor:

What must an artist do to receive proper recognition for a job well done at a convention?

For the 800 conventioners attending the concert at the Pickwick Theatre, Tom Wibbels did not disappoint them. Concert offers were being made before Tom left the theatre.

Carroll Copeland, Program Chairman at the Long Center for the Performing Arts in Lafayette, Indiana, said it best when he printed his 1986 concert brochure to read, "Tom Wibbels is a master of improvisation and a real crowd-pleaser. Received a standing ovation and calls for 'more!' at the 1985 convention."

Within minutes Tom had his audience intrigued with his registrations and technique and relaxed with his audience rapport. There were many selections throughout the concert where Tom received over 30 seconds of applause after individual numbers.

What was the reasoning of not reporting any of these positive aspects of the concert to ATOS readers who could not attend the convention? Is this the press Tom and other very talented convention artists must look forward to even though their performances were well-done and well-received?

Impro International will stand behind the above statements by offering a free "unedited" tape of Tom Wibbels' convention concert performance to any chapter or concert promoter. Please write to Impro International, P.O. Box 1072, Elkhart, Indiana 46515, or call 219/679-4061.

Sincerely,
Trudy HERNICZ, Manager
Elkhart, Indiana

Dear Sir:

I'm the lucky and only owner of a duplicate of the Ken Griffin TV films from 1954/55 of the series "67 Melody Lane," made in the Wurlitzer studios (THEATRE ORGAN, May/June 1985). In one of the films there is a very clever organist named Margie Manor, playing the electrostatic reed Wurlitzer. I wonder if anybody could please give any information about this organist? I have never, until the films appeared, either heard about her or seen any picture in any of the organ magazines in USA and Europe. She is/was American, that's the only thing I know.

Sincerely,
Wilfred Hosteland
Welhavens Gate 12
N-5000 Bergen
Norway

Dear Editor:

I'm trying to get a tape of someone playing the big Barton organ in the Chicago Stadium. I'd love to hear what this big organ sounds like. I understand that Al Melgard was organ-

ist there for 40 years.

If any member of ATOS knows of any music on the Barton organ would they please write to me with information. I would be very grateful for a cassette tape of this organ.

Thanking you most kindly.

Yours very sincerely,
Laurie Morley
21 Riversdene
Stokesley
Middlesbrough
Cleveland TS9 5DD
England

Dear Bob:

Dr. Walter J. Beupre was initially puzzled by Arnold Loxam's "March — Schiedam" ("For the Record," THEATRE ORGAN, September/October 1985). We Europeans recognise it as Arnold's tribute to the Dutch folk who have invited him to play for them on many occasions, frequently at the lovely Standaard 3/10 of the Passage, Schiedam (a Rotterdam suburb).

I don't have any inside information, but it would not surprise me to find him writing something titled "De Poort" to recognise another of what will soon be the four working theatre organs in the Rotterdam area.

Which reminds me. Oskar Heim, in the same issue, finds the word "Orgel" attractive. So do the Dutch, for whom it is the word for "Organ" (and the same goes for German, Danish, Swedish, Norwegian and Icelandic).

Sincerely,
Tony Bernard Smith
Rayleigh, England

Dear Officers and Directors:

Last summer while attending the ATOS convention in Chicago, I noticed an inscription on the side of a school building:

"The foundation of every state is the education of its youth." — Socrates

It is evident to me that this applies to ATOS as well as to our government. We must make ourselves known to all of the younger generation and not just to the young musicians. Your membership drive contest has sparked me and my wife to give this matter considerable thought, and along with our experiences of trying to get new members, we have come up with the following suggestions.

We have discovered that very few people have ever heard of a theatre pipe organ, let alone actually heard one played. When they hear you say pipe organ, they automatically think of church music and are no longer interested in what you have to say. They need to be informed.

1. It might be possible to have a TV show patterned after the show "Evening at Pops," which features the Boston Pops Orchestra.
2. Try to get the national TV networks to use bit parts featuring various theatre organs and artists.
3. Try to get some of our artists on some shows such as "Real People" or "PM Magazine."
4. Maybe a movie could be made about the

life of some prominent organist or organ builder or even about the history of the organ itself. We need to get the theatre pipe organ back in the public eye.

Chapters that have organ concerts should advertise them in nearby towns (150-mile radius) at least two months or more in advance. They should also enlist the aid of members that live in these nearby towns so they could arrange for group trips to these concerts. Travel agencies should be made aware of these concerts. Churches, YMCA, YWCA and public libraries should be notified. Hotels and motels could be informed for the convenience of their guests.

Individual members should invite prospective new members to their homes to explain to them what ATOS is all about. They could sponsor parties for young people to initiate them to theatre organ music (play recordings if necessary). Individual members and their families could take part in local community parades with posters advertising ATOS. Posters could be placed around the community on various bulletin boards in drug stores, laundromats, libraries and civic centers. Do not overlook music stores and music schools.

Individual members could also be encouraged to give gift memberships for birthdays or anniversaries or any other appropriate occasion.

Has anyone considered having a reduced membership fee for young people under, say, age 21? This would help generate membership among college students while their finances are at a low.

It might be possible to get some financial support from some of the foundations that provide financial aid to various nonprofit organizations, to help finance some of the suggestions that obviously could be quite expensive.

Last October while visiting our daughter in Virginia Beach, Virginia, we contacted some of the local members of ATOS and had a very enjoyable time. Unfortunately, we did not have time to meet all of the members personally. I believe this could add a new dimension to ATOS. It has allowed us to make new friendships and meet people who have the same interests without waiting for a convention.

Yours truly,
James R. Weber
Decatur, Illinois

□



CHAPTER NOTES

Edited by Grace E. McGinnis

ALABAMA Birmingham

205/942-5611 or 205/664-3606

WOW! How do you top a wonderful summer and an even better autumn? We have certainly had an exciting year, and 1986 promises to "top all." October's meeting held many surprises — our first "Home Show" — when many of our talented members who love to play, but don't want to do a full program, got to show-off on the Mighty Wurlitzer. Vice-Chairman/Program Director Gary Jones gathered (roped and tied?!) those members wishing and willing to participate and presented them as a group of exciting new "Stars." Some have even committed to solo work in 1986!

On October 27, Tom Hazleton brought the house down in a concert that will go on record as one of our most successful ever. A large, responsive crowd, a wonderful sounding organ and a gorgeous theatre only heightened Mr. Hazleton's dazzling performance. His beautiful arrangements, fresh styling and clean registration left the crowd begging for more. Chairman Cecil Whitmire commented that "it just doesn't get much better than this."



Hardworking Linda Bagwell boxing popcorn in the lobby of the Alabama Theatre. (Gary Jones photo)

Buffalo, New York
716/937-3592 or 716/826-2081

England's talented young organist, Robert Wolfe, played Shea's Buffalo Theatre last November and attracted the largest audience to a Shea's organ concert since the re-dedication of the organ in April 1984. Since making his American debut in 1983, Robert has gained a sizeable following in the northeastern United States and southern Ontario, Canada, as he tours the Lake Ontario concert circuit. Indeed, many people who caught one of his six concerts in October made the trip to Buffalo to hear the "Wizard of the Wurlitzer" perform there. Part of his popularity must lie in the fact that this energetic 23-year-old probably delivers the most music an artist could pack into a concert. By actual count, Robert's performance at Shea's included 71 tunes ranging from novelties to television themes and Broadway hits, and from marches to rags and English quick-steps. One medley included songs whose titles contained the names of flowers, another featured tunes made famous by Al Jolson, and the music just flowed on and on. Wolfe's unique style and technique earned him standing ovations both at intermission and at his final offering. What a pity he spends only one month on this side of the Atlantic Ocean.

MAUREEN WILKE

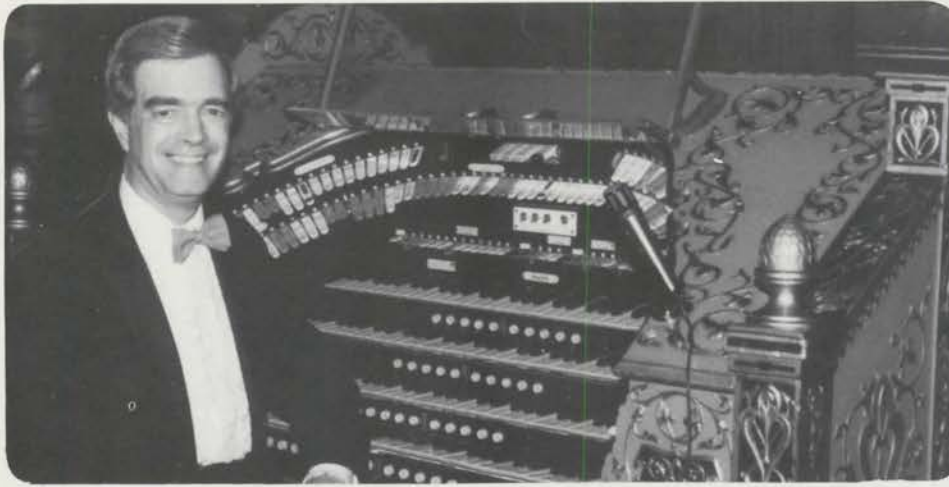

Tom Hazleton at the console of the Alabama Theatre's 4/21 Wurlitzer.

(Gary Jones photo)



Alabama Chapter "Home Show" participants, L to R: Cecil Whitmire, Vince Yester, Kerry Bunn, Christine McPhearson, Bob Johnson, Freeman Andress and Bryan Black.

(Gary Jones photo)

Member Gary Jones journeyed north in October for an "Ohio Organ Adventure" with stops in Cincinnati and Toledo. He was graciously welcomed into the home of Herb and Laverne Merritt whose 2/8 Wurlitzer home installation is outstanding! Other organs he visited included the Shadynook Restaurant's 4/30 Wurlitzer, Evan Chase's 2/5 Kilgen and the Ohio Theatre's four-manual Marr & Colton in Toledo. He also viewed Bob Teska's four-manual Hinners console. Gary obtained quite a few organ parts for addition to the Alabama Theatre's 4/21 Wurlitzer.

November 10 found us "cooling off" inside the Alabama Theatre as temperatures steadily dropped. The Costa/Head organization (owners of the theatre) has been busily preparing the heating system for a mid-December turn-on. Still, our hearts and souls were warmed by an exciting program by Bob Van Camp, house organist at the Fox Theatre in Atlanta. Bob, who is no stranger to our organ, always does an excellent job, but many listeners commented about his exceptional performance on this occasion. This listener was entranced as Bob played Gershwin and Porter medleys (my kinda music!) and showed off his extreme versatility with an arrangement of "In A Persian Market."

GARY W. JONES



GRACE E. MCGINNIS.

CHAPTER CORRESPONDENTS PLEASE NOTE

To help ease the burden on the editorial staff of THEATRE ORGAN, please observe the following:

Type all copy, double-spaced, on letter-size (8½" x 11") white paper, leaving 1¼" margins on top, bottom and both sides. Do not use erasable paper. Please include your name, address and telephone number.

Type photo captions on Scotch (3M) Post-it Note sheets (#654 - 3" x 3" or #655 - 3" x 5") and attach to *back* of photo. DO NOT use any kind of tape or rubber cement to attach captions to photos, and DO NOT attach photos to sheets of paper.

DEADLINES

November 15 for January/February

January 15 for March/April

March 15 for May/June

May 15 for July/August

July 15 for September/October

September 15 for November/December

Send Chapter Notes and photos to:

Grace E. McGinnis, Associate Editor
4633 SE Brookside Drive, #58
Milwaukie, Oregon 97222



Rob Calcaterra at the console of the Style 235 Special Wurlitzer in the Paramount Theatre, Cedar Rapids, Iowa. (Francis Camizzi photo)

CEDAR RAPIDS AREA

Iowa

319/362-9676 or 319/396-5653

On October 5 we scored a magnificent number 32 with the latest in our history of successful concerts. The site was the opulent and majestic Cedar Rapids Paramount Theatre, the organ its extraordinary Style 235 Special scroll Wurlitzer, and the artist was a young and vibrant Rob Calcaterra. His return appearance was highlighted by the fine accent lighting by the Paramount's stage crew. A master of multiple languages, Rob used simple English to attain console presence and generate a rapport with the audience. Buoyed by their enthusiasm, he responded with an exciting variety of tunes which spanned 20 to 40 years in dates of origin.

Much credit for the near capacity crowd goes to ticket chairman John Hockaday and maintenance chairman Jim Olver. The show came off without so much as a single cipher! Still newsworthy after 16 years of chapter concerts, the artist, console and chambers were the subject of a short news feature by local TV personality Kevin Kendall. After the last photos were shot, Rob and members, joined by the stage crew, assembled at a nearby salad bar to celebrate.

We not only have our own local performing arts center to enjoy for socials, but also a fine alternate venue to use for concerts. In lieu of the Paramount, the Kirkwood Community College houses our Style E Wurlitzer (circa 1924). The September 9 pre-concert social was held in the newly redecorated ballroom of Iowa Hall. The added oak and antique white decor blended with accent lighting to create a rare atmosphere. New members Chuck and Melinda Collingwood were introduced, a Chicago Convention update was given by delegate George Baldwin, and open console followed.

Musically, George's stylings became an accordionist's prelude at the Shrine Paramount concert on September 20. While the occasion was unique, the headliner was none other than Myron Floren of Welk fame. Performing prior to Shriner events is "old hat" to George, who dons his fez every spring before the Easter show. Also, in a more spiritual vein, the 3/11 Wurlitzer came into the spotlight during the "Best of CR" gospel concert on October 27. Performing the special repertoire was Harry Christiansen, veteran organist at First Lutheran Church in Cedar Rapids. Also of interest to the faithful will be the return engagement of Father Jim Miller at the Paramount console this spring.

MICHAEL VANCURA

CENTRAL FLORIDA THEATRE ORGAN SOCIETY

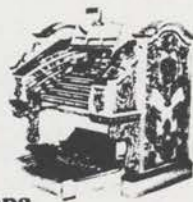

Tampa

813/685-8707 or 813/734-5721

We have really been progressing this year. The rebuilt Tampa Theatre Wurlitzer, which was re-dedicated last month, has concerts for silent movies each month, and other events have made this year a first for our society. Each month our membership seems to increase and more interest is shown at each meeting. Thanks to the hospitality of Ken and Ruth Hunt in Clearwater, our members have been able to hear and play their magnificent Wurlitzer.

Our last meeting was held at Roger and Dottie Bloom's in Hudson and brought out 31 of us to their beautiful home to hear Dottie play their Conn 652 and to have open console.

As our area is growing, so is our organization, and we hope that any of you who would be in our area could attend our meetings and hear our wonderful organ at the Tampa Theatre.

PAUL T. DANIELSON



CENTRAL INDIANA CHAPTER

Indianapolis
317/255-8056
or 317/786-2160

President Tess Moses opened the October 13 meeting at the Hedback Theatre. Tim Needler covered tentative plans for the Humane Society Benefit now scheduled for April 6, 1986. Our entertainer for the day was Brian Holland who needs little introduction. In addition to being a fine organist, he is an ardent worker at meetings and events. Open console at the Page organ was next in order.

Our November meeting was held at the Pipe Dream Restaurant in Kokomo. Following the business meeting, Dr. Jack Elleman, owner of the Pipe Dream, introduced staff organist Rob Richards who presented a program which demonstrated the new sweet sound that is now the pattern for music desired by patrons. The Pipe Dream is now a full-service dining facility. The organ is a 3/12 Wurlitzer originally installed in the Claremont Theatre in New York. It went next to Chicago's Irving Theatre, was rebuilt in 1929 and moved to St. Procopius College in Lisle, Illinois. In 1980 it was moved to a home in Cleveland, Ohio, until it came to Kokomo in 1981, where it has been rebuilt once more. After Rob completed his fine program, open console was held.

WAYNE R. PIPHER

CENTRAL OHIO

Columbus

513/652-1775 or 614/882-4085

September 28 marked Western Reserve Chapter's weekender in our territory. We were pleased that they chose ol' Columbus town and felt privileged to have them see and play our 3/16 Wurlitzer in the Worthington High School auditorium. Along with their President, Al Bohmlein, we welcomed back organist Bill Taber who is no stranger to us. The weekend tour included visits to Larry Krueger's 2/12 Wurlitzer installation at Capital University, the Ohio's 4/20 Robert-Morton where they were given a tour of the theatre and a demonstration by resident organist Dennis James, and a Sunday morning visit to St. Joseph Cathedral which houses a 21-rank Wicks.

On September 29 we met at Worthington High School for our annual meeting and election of directors. Over 40 members and guests heard from our own keyboard artists, among whom was new member Trent Sims, not only a competent organist in his own right, but also



Don Reighard, Mark Williams and Harry Connnett, new and re-elected board members of Central Ohio Chapter. (Jack Montag photo)



Trent Sims at the console of Central Ohio Chapter's 3/16 Wurlitzer in Worthington High School. (Jack Montag photo)

a qualified technician in theatre organ building and repair.

October 9 was an occasion to take three ranks of strings from our Wurlitzer to Bud Schoppe in Alliance, Ohio, for wiring and repair. This has been, and continues to be, a rewarding experience, to see the manufacture of organ pipes — from smelting to voicing — all under one roof. It is also reassuring to know that, in this modern day and age, pipe organs are still being built. We reaffirmed our belief that there are vast numbers of people out there who won't settle for less than the real thing — the reverberant response of blown pipes.

JOHN R. POLSLEY



Chicago Area

Theatre Organ Enthusiasts

312/470-0743 or 312/627-3245

Our first show after the 1985 Convention was held at the Arcada Theatre in St. Charles. We were privileged to have Gaylord Carter as our soloist and to hear his excellent program on the Marr & Colton. This organ, built in 1927, was later rebuilt by the Geneva Organ Company into a 3/16 with Echo Division. This show was enhanced by magician Bruce Walstad and his fast-paced fantastic presentation of comedy and magic. Also, a Harold Lloyd short was shown along with a Disney cartoon and a sing-along. These are delightful occasions.

The following week many sturdy members and guests went to the Aragon Ballroom for a 9:00 a.m. social. Brian Durack, a local chap, was the soloist on the 3/10 Wurlitzer and gave an excellent nostalgic program which was followed by a generous open console time.

November entered with a social at the beautiful Rialto Theatre in Joliet. Talented Lee Maloney, a Joliet Chapter member, was the

soloist on the 4/21 Barton Grande. It was a delight to all present, and ample time was included for open console playing.

Our second fall show was at the Patio Theatre which possessed hints of nostalgia with its vaudeville format. Bill Kucek was soloist on the 4/17 Barton. Bill has been organist for the Axel Roller Rinks in this area and, at present, is head organist for the Elm Roller Rink. His selections fit well into the mood of the program. Our emcee was the humorous and versatile Charles Cooney. Also on the program was Martin Ellis, winner of the ATOS Young Organist Competition recently held in Chicago. This is a young man to include in your listening list, as he is an outstanding talent. We were pleased to have Leon Berry and Hal Pearl, popular local organists, in the audience. Then, debuting on our program, was the MTM Stage Band, a group of accomplished local young musicians with excellent past performances. Two of the boys in this group are Rieger brothers, Jim and Larry. Jim Rieger also does arranging and general

management. Added variety were Karen and Leslie, a dance duo, who possess excellent training and performance ambitions for the future. All of which made for delightful entertainment for the almost full house. An added touch of class was the red and white uniformed Hospitality Group with a member at each aisle and in the lobby.

Note to chapters: you might consider adding extra entertainment to your organ shows to attract people, young and old, to hear theatre organs.

Did you know that the Riviera Theatre on Chicago's north side has been refurbished and is now a night club? The Uptown Theatre is quietly going through a renovating, and a pipe organ may be included. The State-Lake is now a TV studio complex, and the Chicago Theatre is now closed for remodeling. Rumors are that the Southtown Theatre is being worked on for a presentation house or whatever (?). Time will tell more about these activities in the not-too-quiet Midwest.

ALMER N. BROSTROM

Moving?

Send your
change
of address
to . . .

**ATOS
Membership
P.O. Box 420490
Sacramento, Calif.
95842**



**Milwaukee
414/463-2365
or 414/771-8522**

Tom Gnaster played our September concert at the Racine Theatre Guild. A good crowd of organ fans braved torrential rains to hear Tom's delightful program on the Wurlitzer.

Garrison Keillor brought his "A Prairie Home Companion" show to the Riverside Theatre on October 11 and 12, and the Mighty Wurlitzer, with our own Gary Hanson, was part of both shows. This program is broadcast on more than 260 public radio stations with an estimated two million listeners. At the Friday night performance, Gary showed off the organ with "Birth of the Blues," followed by a march that got the audience clapping and whistling when he got to the chorus of "On, Wisconsin!" Told by Mr. Keillor to "press the schmalz stops" at the

Saturday broadcast, Gary played a beautiful, very orchestral arrangement of "Vienna, City of My Dreams." This was wonderful exposure for the theatre organ, and we're very proud of Gary and the beautiful Riverside Wurlitzer.

Halloween found us in the basement theatre of Fred and Veryl Hermes in Racine. Long-time Dairyland friend Kay McAbee was the guest artist. Kay is no stranger to the five-manual Wurlitzer and played many of the arrangements that have won him quite a following. Fred Hermes accompanied a clip from *The Bride of Frankenstein*, then allowed open console. Thanks to the Hermes' for a great spooky time!

On November 8 the Riverside celebrated the first anniversary of its renovation with a special broadcast on WTMJ radio. Though we were barely tolerated a year ago, the new theatre management has realized what a valuable asset the organ is and how much our members have contributed. As a mark of this, the organ was again a broadcast feature. Chairman Fred Wolfram was interviewed, and Gary Hanson did the console honors. Gary gave a short demonstration of the organ's voices and accompanied the audience as they sang "Happy Birthday" to our beautiful theatre.

The timing of that broadcast was just perfect as Jonas Nordwall made his first appearance for us on November 10 at the Riverside. From his opener, the appropriate "Down By The Riverside," to his encore, the best arrangement of "Bridge Over The River Kwai" this reviewer has ever heard, Jonas presented an exciting and varied program ranging from toccatas to rock to things not often heard, including a musical commentary on the Bhagwan Rajneesh. A master of registration, Jonas coaxed many unusual, but effective, sounds out of the Wurlitzer. We hope this was the first of many appearances Jonas will make in Milwaukee.

Last, but not least, we have been given a wonderful gift, the 3/10 Barton originally installed in the Colonial Theatre in Milwaukee. Unfortunately, the organ suffered some vandalism — all the metal pipes were stolen, but we are going to replace the missing ranks and are looking into suitable sites for installation. A theatre in Oshkosh is a strong possibility as it would be appropriate for the instrument to return to Dan Barton's city.

CARRIE NELSON



Babson College, Wellesley
617/662-7055

Our fall season got underway at Babson on September 22 with organist Robert Love. Although he is essentially a church organist, Robert's love of theatre organ shines through in his playing. Years ago he used to practice on the now gone 2/5 Wurlitzer in the Strand Theatre in Malden. In addition to his teach-

ing, Robert has 25 years tenure at the big Skinner in the First Baptist Church in Malden and is listed in *Who's Who in Music*. Mr. Love knows how to hold an audience's attention from his well-played Sousa march to his ambitious orchestral transcription, "Bridal Rose Overture" and fine medley from *The Wizard of Oz*. Well-deserved appreciative applause brought us an encore of familiar movie music as he "rode off" to "Boots and Saddles." Bob thoroughly enjoyed himself on our restored 235 Special, and so did we. He would have made a fine theatre organist with his "feel" of a unit orchestra, his colorful registrations, his broad range of all musical types and his ability to transmit this to his listeners.

Our long-anticipated weekend with Walt Strony, October 19 at Stoneham Town Hall and October 20 at Babson, is now history, but what memories! There is little need to describe this man's talents as his impressive rise in the theatre organ world certainly speaks for itself. From his National Convention concerts, his appearances across the nation and overseas, his recordings, his pizza parlor organ playing to his position as a church organist, he is truly one of the most successful and active young artists on the scene today. Walt is a perfectionist, first and foremost; his mind is fertile, and what those busy hands and feet cannot produce in wonderful music isn't worth mentioning. Fortunately for us, neither the Stoneham 2/14 Wurlitzer nor our 3/13 "complained" once.

The Stoneham concert's bouncy opener was Berlin's "Piccolino," and his program included one of his favorite Porter compositions, "I Love You," and a great Glenn Miller arrangement of "Moonlight Serenade." After intermission, a brisk Sousa march and two Gershwin beauties led us into the very well-played silent *Cops* with Buster Keaton. A spectacular "Tico Tico" finale engendered such enthusiasm that we were not to be denied. Walt let the audience suggest songs, and he obliged with many, of which an unusual "Hoedown," from *Rodeo*, stood out. He finished with "New York, New York." My notes read, "Great concert — imaginative arrangements" — which says it all!

"Putting on the Ritz" was the classy opener at Babson, and a fine medley from *The King and I* followed. After his fiery "Maleguena," Walt mentioned "having a ball — everything works!" and credited both organ crews for both instruments. After the sing-along and a brisk "That's Entertainment," the silent movie brought to many the happy memories of Saturday afternoons at the show. For a 30-year-old "youngster," Strony has that touch. A return to the console after the standing "O" and shouts of "More!" was a must, and five pop numbers resulted in another standing "O" which gave us an amusing "Oscar Meyer Weiner." It is certainly easy to see why this versatile Al Melgard-trained organist is in such demand. His particular style, his respect for the traditions of theatre organ, his engaging console personality and his forward-looking approach insure Walt's mark in the annals of theatre organ.

Our October 27 Babson meeting had a sur-

prise guest artist, long-distance member Mark Renwick, now of Jacksonville, Florida. He was up for a last look at his former Sudbury home as his parents, Marge and Erle Renwick, are also moving to Jacksonville, to our great loss as all have contributed much over the past 19 years. Mark, while being away from a theatre pipe organ, has been fortunate to have access to the large three-manual Austin in St. John's Cathedral of the Episcopal Diocese of Florida. In fact, he was given permission to present a theatre organ program last June as one of a series of five evening concerts. This was greatly appreciated by the largest audience in the series. This personable young man has lost none of his theatre organ technique as displayed in his all-too-brief program of "Golden Oldies." Members and friends gave Mark a good hand at the conclusion of his encore, "Meditation," and one that he'll not soon forget. We hope that he will visit us again soon.

STANLEY C. GARNISS



**GARDEN STATE
THEATRE ORGAN
SOCIETY, INC.**

New Jersey
317/786-2160
or 317/255-8056

The National Convention in Chicago drew about 35 of our members for a busy, enjoyable, music-filled six days of theatre organs. Coming from "Wurlitzer/Möller Land," we especially enjoyed the lovely sounds of Barton organs. Socially, the convention was a cacophony of lining up for buses, chatting with members from all over the country as well as from England, Canada and Australia, eating great food at surprisingly low prices, taping all the concerts and photographing Chicago's impressive skyline and theatres, especially the beautifully restored ones.

One of the highlights for us was the wine and cheese party attended by all of our members. We were delighted to have six of our past and present chairmen present: Bob Balfour, our founding chairman; Irving Light, Peter Panos, Bill Smith, Jack Moelmann, and our present chairman, Mike Cipolletti. Jack, resplendent in his white Air Force uniform, announced his election as ATOS National President. Much applause and good wishes followed. We know that Jack will be an excellent president and will keep things moving.

On September 8 an interesting meeting of Garden State and New York Chapters was held at the "little" Carnegie Hall Cinema in New York City. Ben Hall's famous "Little Mother" 2/6 Wurlitzer resides there and is currently maintained by ATOS under the leadership of board members Ashley Miller and Allen Miller. The open console and social drew members from both states who enjoyed the first joint meeting of the chapters in many years.

The first of the Trenton Concert Series took place at the Trenton War Memorial on



Gaylord Carter in his most comfortable environment, gathered with friends and reminiscing about theatres, films and music. (Don Bissell photo)



MC Jerry Adams, Gaylord and Vera Walling, the hostess for "Gaylord Carter and Friends." (Don Bissell photo)



Chairmen of Garden State Chapter, L to R: Founding Chairman Bob Balfour, Bill Smith, present Chairman Mike Cipolletti, Col. Jack Moelmann, Peter Panos and Irving Light.

September 29 with guest organist Leroy Lewis at the 3/16 Möller. Leroy is a very entertaining performer who uses inventive stylings and pleasing new registrations. An unusual addition to his program was an excellent drummer, Kevin Kelton, who added rhythmic accompaniment to many popular Broadway show tunes. During the concert, a newly published song entitled "New Jersey, Here's to You" was introduced. It has been gaining popularity throughout the state. Mrs. Marie Hoffman, who composed the music, was introduced to the audience. The concert concluded with a Laurel and Hardy silent film, and was followed by the usual social on the stage.

JINNY VANORE

LAND OF LINCOLN
Rockford
815/965-0856 or 815/399-8536

An evening with Gaylord Carter and friends began with his letter to charter mem-

ber and long-time friend Vera Walling and ended with a delightful social of musical reminiscing and entertainment in true theatre organ style as only Gaylord can deliver. Gaylord wrote that he would be in the Rockford area during September and would enjoy a visit with friends. Also, if it could be arranged, he would play a social for members and guests during his stay. Time schedules were checked and arrangements made and, on September 8, Jerry Adams, Vera and Barb Nicol met Gaylord at O'Hare.

Since it doesn't rain in Gaylord's state, we were able to treat him to a splendid display of Illinois weather. From a blistering 95° to a classic thunder 'n lightning, cloudbursting rain storm, black clouds after blacker clouds — we had it all.

On September 9, what was to have been a small social became one of the largest we have ever sponsored, and probably one of the most memorable as well. Beginning with the introduction by Jerry Adams, and hearing the opening notes of Carter's theme, one sensed this was to be a "perfect" evening. The grand

old Barton was in excellent condition, and Carter's familiarity with the instrument facilitated registrations, making it look all too easy to the initiates in the audience. As usual, Gaylord established that bond between audience and performer with a variety of selections. Bringing out background information about composers or the music transported us from one era to another. There was something for everyone.

Following the performance everyone was invited to the afterglow and the generous, tempting array of goodies. Meeting and chatting with our genial guest and exchanging pleasantries with each other brought the evening with Gaylord Carter and friends to a happy end.

Gaylord Carter is known as the dean of silent film organists, but at age 80 he may be tagged with another title. He has video-taped accompaniment to the silent film *Wings*, the Buddy Rogers and Clara Bow classic, and others may be available in the near future.

BARB NICOL



LONDON
&
SOUTH
OF ENGLAND

8956-32369 or 1-788-8791

Two events in late October marked a double anniversary celebration absolutely unique in the theatre organ world: the Golden Wedding of those beloved friends of the theatre organ the world over and honorary members of ATOS, Les and Edith Rawle, and the Silver anniversary of the world-famous 3/19 Wurlitzer in their hospitable home at Northolt in Northwest London. Their 50 years together have been characterized by a passionate love of, and devotion to, the theatre organ, from the earliest days in their native Wales through the complete cycle of theatre organ in Britain. Being arguably the first in this coun-



Geoffrey Solman, 1983 Dean Herrick Award winner, and Graeme Wright at the Granada Slough Wurlitzer.



Edith and Les Rawle cutting the cake at their fiftieth wedding anniversary party at the Granada Slough on October 27.

try to install a theatre pipe organ in their own home, built for that purpose, what began as the flood-damaged 3/8 Wurlitzer from the Granada Wandsworth Road in South London, and on through successive pipework additions and a new music room, has now become the most frequently played theatre organ in the world. Two simultaneous reasons, therefore, for us to enjoy a fabulous weekend together with the focus on our universal love of the theatre organ and, of course, on Edith and Les as an integral part of it.

So it was that our October Chapter Club Night at Wurlitzer Lodge, justifiably for this occasion, brought Edith and Les to the fore. Our featured artist naturally had to be their well-known organist son Len, the only "resident" that the organ has ever had, who (on the eve of his concert tour of Australia) provided a veritable cavalcade of the popular tunes that his parents had enjoyed and which had characterized their half-century together, all with his inimitable style and enthusiasm. Among the many celebration gifts and good wishes, our chapter presented Edith and Les

with a large floral tribute together with the new Piccadilly seven-record collection of "George Wright Plays Organ Classics" in recognition of their great admiration of George's unique artistry and as a token of our thanks and appreciation for their exceptional kindness and friendship to us all over so many years.

Two days later, on their actual Golden Wedding day, found us at the beautiful Granada Slough with its brilliant late-model (1937), 3/8 Wurlitzer. With the console placed behind the wide-screen of the now tripled auditorium, we currently feature it on closed circuit television.

With the great news that Granada Theatres have given us permission to re-install the console in the auditorium of Cinema 1, our artists were talented young Geoffrey Solman, to represent our dedication to the rising generation, together with seasoned and widely accomplished Graeme Wright, who is professionally a senior executive and demonstrator for Farfisa and Bontempi. As is now our practice, our pre-concert young starlet at the Yamaha

electronic in the foyer was lovely Jayne Darley of Ascot. Dena Cooper played during the main interval. This happiest of chapter concert days was then marvelously rounded off with an intimate relaxing celebration in the circle foyer of the theatre with Edith and Les cutting a magnificent three-tier cake and, of course, the characteristically superb buffet prepared and served "ATOS London Style" by Edith and our team of ladies. All-in-all, a unique double celebration for and with two very special people who normally prefer to be "in the wings," but who justifiably held "center stage" for this most memorable and enjoyable weekend of theatre organ fun and fellowship.

Two weeks later the celebration mood again prevailed at the world-renowned Granada Tooting when around 50 members were privileged to pay an informal visit to see and hear the 4/14 Wurlitzer there. Our Technical Team showed us "the works" which they have so admirably restored after the disastrous flood damage of more than a decade ago. Our ladies provided refreshments, and several members had a "go" on this magnificent instrument (including John Sharp, our photographer par excellence, himself a Granada organist) which we fervently hope will soon be available for public presentation again.

DR. NORMAN BARFIELD



LOS ANGELES
THEATRE ORGAN
SOCIETY

California
818/792-7084

Our fall season opened with Ramona Gerhard returning to the San Gabriel 3/16 Wurlitzer for an evening of her dynamic artistry.

On October 6, John Ledwon, former Chairman, hosted an open house and business meeting at his now completely restored home which suffered such destruction during the horrible Agoura fire several years ago. His magnificent 3/29 Wurlitzer is finer than ever, and John was the first of a parade of organists



London Chapter members, R to L: Michael Wooldridge, Janet Dowsett, Dennis Gibson, Bob Taylor, and Les Solman partaking of the buffet at the Rawle's anniversary party.



John Ledwon (center) and Donn Linton (left) listen as Dick Loderhose makes a point during LATOS meeting in John's home. (Zimfoto)



Keith Chapman at the Pasadena Civic Auditorium Möller during his LATOS-sponsored concert. (Zimfoto)

to play it on this gala occasion. About 125 members attended the five-hour event. At the brief business meeting, Ralph Beaudry was presented with an Honorary Life Membership in LATOS.

In his first West Coast "pops" concert, we presented Keith Chapman at the five-manual Möller in the Pasadena Civic Auditorium in October. Closing the fall season were Cheryl and Wayne Seppala at the San Gabriel Mighty Wurlitzer.



Detroit
313/537-1133

Ashley Miller appeared in concert at the 3/10 Barton at the Redford Theatre on September 14 with a program that delighted a very receptive audience. At Ashley's request, Melissa Ambrose, winner of the Motor City Young Organist Competition at Redford and runner-up in the ATOS National Young Or-

ganist Competition, performed several selections in a special cameo performance. The two then played a duet with Melissa at the organ and Ashley at the grand piano on stage.

Tom Wibbels won the hearts of his audience in a concert at the Redford on October 12. His dramatic rendition of "In The Hall of The Mountain King" was a most appropriate vehicle to feature Igor The Magnificent, a mechanized monster seated at the pit piano. The brainchild of Tom Hurst, David Martin and Richard Lerman, Igor's head turned toward the audience (thanks to a remote-control antenna rotor), and his red eyes blinked on and off, seemingly at will, during the number. Tom's standing ovation was testimony to a beautiful concert, and we are looking forward to having him back again.

Our annual membership meeting was held at the Redford on November 3 and was preceded by a catered dinner in the lobby. Dinner music was provided by Lou Behm at the Barton. Following dinner, Lou accompanied Jerry Skelly as he sang "The Wedding Prayer" in honor of Jim and Alice Dunn's fiftieth anniversary. An impromptu sing-along ensued, led by Fran Carmody.



Ramona Gerhart at the San Gabriel Civic Auditorium 3/16 Wurlitzer. (Zimfoto)



Vocalist Fran Carmody and organist Dennis Minear performed at Motor City's Fourth Sunday program at the Royal Oak Theatre in September. (Fred Page photo)



Larry Peck played the Royal Oak Theatre's 3/16 Barton for Motor City in October. (Fred Page photo)



Igor and his creators, David Martin and Richard Lerman, with artist Tom Wibbels following Tom's concert at the Redford Theatre in October. (Bo Hanley photo)



Ashley Miller asked Melissa Ambrose, the runner-up in the ATOS Young Organist Competition, to be a cameo artist at his September concert at the Redford Theatre. (Dorothy Van Steenkiste photo)

Club Day, which gives members an opportunity to socialize and to play the Barton at the Redford, was held on September 1 and again on October 6. Workshops preceding each event dealt with familiarization with the console and registration tips.

Wilma Steslick, John Lauter, Grace Joslin, Don Haller and Stan Zimmerman provided overture and intermission music for our popular biweekly film series at the Redford.

Dennis Minear presented a variety of music at the Royal Oak Theatre as the artist for our Fourth Sunday concert on September 22. As an added attraction, Dennis called upon vocalist Fran Carmody whose great song stylings need no amplification.

"Music That Brought Back Memories of Magnificent Movie Palaces and The Grand Theatre Organ" was the theme of Larry Peck's program as he performed at the 3/16 Barton for the October Fourth Sunday event at the Royal Oak.

Coming events include Lyn Larsen and Carlo Curley at the Redford on March 1, Ron Rhode at the Royal Oak on April 12 and Gaylord Carter's farewell concert at the Redford on May 10. For more information write: Motor City Theatre Organ Society, 17360 Lahser Road, Detroit, Michigan 48219, or phone 313/537-1133.

DON LOCKWOOD

**NEW YORK
THEATRE ORGAN SOCIETY
New York
914/343-1756 or 201/694-0779**

We began our busy fall season with a concert on September 19 featuring Rob Calcatera at the 4/26 Brooklyn Paramount Wurlitzer at Long Island University. Rob's varied and balanced program demonstrated the versatility and resources of both the organ and the talented artist. Rob opened with a rousing "It's A Good Day" and included two classical selections, "Le Cuckoo," with a Baroque flavor, and "Fanfare" by Lemmen, which took

advantage of the unique acoustical characteristics of the former theatre, now a gymnasium, to produce a cathedral effect. His beautiful arrangement of "La Vie en Rose," in which the melody line is featured on a Flute in the pedal, was as much a hit at LIU as it was at his concert at the National Convention last summer. With the console situated as it is on the basketball court, Rob surprised the audience by making his entrance for the second half of the concert dribbling a basketball (white tails and all), and, although his set shot was a miss (it worked at rehearsal), his concert was indeed a hit. Following the concert, members had a chance to take their turns at open console and, as always, the instrument was in top condition thanks to members Bob Walker and Gary Phillips who maintain it.

October 19 was another busy day as members and guests boarded a chartered bus to travel north to West Point and on to New York Military Academy in Cornwall for our Hudson Highlands Fall Festival. The first stop was the Cadet Chapel at the U.S. Military Academy at West Point for a concert on the world's largest church organ, the magnificent 4/288 Möller. Our host and artist for the afternoon was Cadet Chapel Organist and Choirmaster Lee Dettra who welcomed us to the beautiful 1500-seat Gothic chapel, which in size and appearance is more like a large cathedral. Following a military wedding which delayed slightly the start of our program (some who arrived early considered it a bonus), Mr. Dettra told us the history, specifications and layout of the organ which is controlled by a horseshoe console containing 1000 stops. He then opened with three movements of a Vierne organ symphony. The tremendous dynamics of the instrument were evident in Lee's arrangement of "Finlandia," by Sibelius, in which registrations developed from the softest Flute Celeste in the Echo Division, took on ethereal qualities with the addition of a Violina and Vox and gradually built to an exciting full-organ ensemble. Lee Dettra's organ artistry was evident throughout his program, and his final selection, Bach's "Passacaglia and Fugue in C Minor,"

left the audience wanting more. Unfortunately, we had to leave the beautiful West Point campus to continue our events for the evening.

Following dinner, the caravan headed for Cornwall-on-Hudson, a few miles north, where several hundred theatre organ enthusiasts from the local area and neighboring chapters gathered for an evening concert by Lou Hurvitz at the New York Military Academy's 4/31 Möller theatre organ. Sergeant Major Hurvitz is currently assigned to Army Band Headquarters in Washington, D.C. Lou opened his excellent program with a bouncy "You Do Something to Me," fol-



Rob Calcatera and bouncing ball at the Brooklyn Paramount/Long Island University 4/26 Wurlitzer.



Lou Hurvitz at the New York Military Academy 4/31 Möller.



Lee Dettra, Cadet Chapel Organist, at the U.S. Military Academy, West Point, 4/288 Möller.

lowed by his theme, "With A Song in My Heart." Highlights included a medley of Jerome Kern standards as well as a beautiful arrangement of songs by Irving Berlin. He accompanied a hilarious Laurel and Hardy comedy and closed appropriately with "I'll Be Seeing You." The appreciative audience called him back for two encores. As he has in past performances, Lou again proved his talent as an accomplished theatre organist. In all, our Fall Festival was a great success providing a delightful day of great organ music and good spirit.

TOM STEHLE

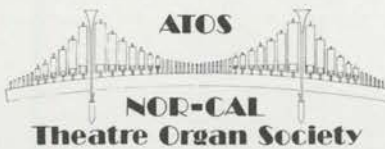

San Francisco Bay Area

415/846-3496 or 415/524-7452

Berkeley Community Theatre was the site of our September 22 meeting. Nor-Cal and Berkeley Unified School District have agreed to the installation of a Wurlitzer theatre pipe organ in the auditorium. The premiere con-

cert artists were Jerry Nagano and Bob Vaughn playing the Rodgers 33-E donated to Nor-Cal earlier this year by Dr. Leon Clark. Nagano played a preview concert featuring many novelty and upbeat tunes. During intermission, spokesman Rudy Frey informed us of the features of the auditorium, introduced manager Judson H. Owens and then gave us an update on the progress of obtaining a Wurlitzer. Bob Vaughn accompanied a 35mm print of Buster Keaton's silent *Sherlock, Jr.* Two 35mm Super Simplex projectors, donated by Sandy Fleet, were used, with member Jim Combs serving as projectionist in the booth. Appropriately, much of the action takes place in a silent movie house with Keaton as hero projectionist-cum-detective. The special visual effects were a delight to the audience, as was Vaughn's expert accompaniment. After the concert, tours of the organ chambers, high above the proscenium, were

Troubleshooting Guide Quiz Answer

See question on page 7.

If the console top lifts easily, raise it and see if the contact behind the stop key is functioning. Then look to the switch stack for a malfunctioning stop switch action. □

given to those wishing to make the climb. Open console followed.

Dave Reese played on October 20 at San Francisco's Castro Theatre. The Taylor brothers' four-manual Wurlitzer has grown to 21 ranks with the addition of a Brass Saxophone and a Quintadena. Dave's console-raiser was "That's Entertainment." "Here's That Rainy Day," done in a nice ballad style, demonstrated some of the softer strings of the instrument. A real toe-tapper was Fats Waller's "Honeysuckle Rose" with second-touch jazz riffs! The second half of his concert was highlighted by "Every Street's A Boulevard in Old New York," dedicated to tonal finisher Ed Stout, and a novelty tune of the twenties, "Egyptian Ella," an 800-pound belly dancer, done in Oriental mysterioso upbeat style. Reese's closing piece was "The Song Is Ended," but the audience wouldn't hear of it. They demanded an encore, and Dave satisfied them with a selection of tunes from *La Cage aux Folles*. The program was one of the best-attended Sunday morning concerts in quite awhile. Thank you, Dave, for a delightful concert.

The writer first met and heard Dave Reese at the Organ Loft in Salt Lake City in 1970. His playing has continued to improve over the



David Reese at the 4/21 Wurlitzer, Castro Theatre, San Francisco, for Nor-Cal concert. (Rudy Frey photo)



Premiere concert duo Bob Vaughn (left) and Jerry Nagano at Nor-Cal's Rodgers 33E in the Berkeley Community Theatre. Speakers are in the pipe chambers. Dr. Leon Clark donated the organ. (Ed Mullins photo)



Spokesman Rudy Frey introduced Judson H. Owens, Berkeley Community Theatre manager, to the Nor-Cal audience. Owens is also a Nor-Cal member. (Ed Mullins photo)



Operator Jim Combs with two 35mm Super Simplex commercial projectors donated by Sandy Fleet to the Berkeley Community Theatre. (Ed Mullins photo)



Entrance to the Berkeley Community Theatre, where Nor-Cal Chapter is installing its chapter organ. (Ed Mullins photo)

past 15 years. The Castro organ is heard nightly with Elbert LaChelle and David Hegarty as house organists. Bob Vaughn accompanied three silent films there in November.

ED MULLINS



**NORTH
TEXAS
CHAPTER**

Dallas-Fort Worth

214/256-2743 or 214/233-7108

Our dream of having a chapter organ playing in a theatre was finally realized on October 20 when we heard our 3/8 Robert-Morton playing — magnificently — in the Lakewood Theatre in Dallas. This dream began in earnest when, in 1977, we were awarded the Wonder Morton from the Loew's Jersey City Theatre. The dream was nurtured through many long years of fund-raising, restoration activity and installation planning. In our continuing search for a suitable large auditorium for our Wonder Morton, we became aware of plans of restoring and reopening the Lake-



ashley miller
a.a.g.o.

MILCO MUSIC CO.
P.O. Box 32 • Closter, N.J. 07624 • (201) 768-4450

RON RHODE
THEATRE
PIPE ORGAN
CONCERTS

KARL WARNER MANAGEMENT
6842 E. VIRGINIA AVENUE
SCOTTSDALE, ARIZONA 85257
(602) 946-6892

Featured at Organ Stop Pizza - 2250 W. Southern, Mesa, Arizona



North Texas Chairman Gordon Wright does some tuning in the Lakewood Theatre pipe chambers, located on the stage.



Partial view of a chamber at the Lakewood Theatre. Stan Guy looks at some of the "big ones."



Lew Williams (light coat) and Gordon Wright before the 3/18 Wurlitzer console in the Wright home. Pipes on the voicing rack are from the chapter's 3/8 Robert-Morton.

wood Theatre, a 1930s neighborhood movie house. We made overtures to the management that were warmly received, and we moved quickly to assess the suitability of the theatre for our organ. What we found was disappointing. The only area available was on the stage, and even this was too small to house our big organ. At this time, members Earl and Donna McDonald offered the use of their 3/8 Robert-Morton, then being stored in their garage. This organ was originally from the Old Mill (later Capri) Theatre in downtown Dallas. Unfortunately, after years of storage and disuse, complete restoration was necessary. Member Gene Powell offered to lead the restoration work and to make available the facilities of his "Organ World" workshop for the activity. Members Dick Cooper and Fred Garrett, who worked on the large organ and are associates of Gene's on another installation, also volunteered to work virtually full time to get the 3/8 rebuilt and installed in the Lakewood. We, of course, gratefully accept-



Charles Evans at the North Texas Chapter's 3/8 Robert-Morton in the Lakewood Theatre in Dallas.

Flicker Fingers Presentations
The Organ and the Silent Screen
Still Going Strong

Gaylord Carter

1371 Paseo del Mar • San Pedro, California 90731
(213) 831-6360

BARBARA SELLERS

*"You heard her at the 1985 Convention,
now hear her locally."*

For Concert Information and Availability

Richard J. Sklenar

3051 N. Clark, Chicago, Illinois 60657

(312) 248-5744 or 525-8658



Dale Flanery made beautiful music during the first program on North Texas Chapter's 3/8 Robert-Morton in the Lakewood Theatre.



Bonghan Yun has a unique way of displaying sheet music on Gaylord's organ. Jerry Gaylord is assisting with the registration. (Claude Neuffer photo)

ed their offers and proceeded with the project.

Early in 1985, after many months of dedicated work by these benefactors and many volunteers, the organ was ready for installation. At that time, Chairman Gordon Wright and organ donor Earl McDonald recruited all available help and undertook the installation including refurbishing all of the pipework. They set a target of September to have the organ ready to play. When the theatre went on a summer schedule of opening at 10:30 a.m. to accommodate the out-of-schoolers, the target seemed to be in jeopardy; however, this dedicated group started coming in at 7:00 a.m. and managed to stay on their original schedule.

In late September, Gordon proudly notified Past-Chairman Irving Light that if he came to the theatre on Sunday morning, he would hear the organ playing, words that Irving had been waiting to hear since the inception of the project. Though not without some dead notes, and only roughly tuned, the rich theatre organ sound was, indeed, pouring from the chambers. Irving admits to a shiver of elation and wonder at hearing this beautiful sound from the organ awakened from its long slumber. And now, at a special meeting in the Lakewood Theatre, the assembled members and friends were treated to the thrill of hearing the lush sound of a theatre pipe organ playing in a large theatre. For some whose only exposure has been to pizza parlor or home installations, the experience of hearing

the sound enrichment and blending that results from this environment was both astounding and thrilling. For others of us, it was a great deal of nostalgic euphoria. We are now planning some initial public exposure and then a concert. This marks a new beginning for our chapter, the culmination of much dedicated hard work and sacrifice. We thank all who have contributed to this great accomplishment!

In September we were given a rare treat, a theatre organ concert by Lew Williams, fresh from his memorable performance at the Chicago convention. We proudly count Lew among our membership as he received some of his musical education in our area and became one of us at that time. It is to Lew's credit that he chose not to repeat his performance in Chicago; in fact, after his first few selections, he asked for requests from the audience and then proceeded to play them all beautifully. For this memorable program, we were the guests of Gordon and Evelyn Wright in their beautiful Dallas home with its 3/18 Wurlitzer. Thank you, Lew, for a most enjoyable musical experience.

IRVING LIGHT

OREGON Portland

503/775-9048 or 503/771-8098

On October 13 we returned to an open house as guests of Jerry and Nickie Gaylord,

whose country home is located in the rolling hills several miles southeast of Portland. Their 2/7 Wicks has a beautiful console built by original owner Bob Rickett who is also one of the founders of our chapter. The organ speaks directly into a very large recreation room with fine acoustics. A large turnout kept the open console well occupied. a guest, Bonghan Yun, used a novel way to read music which required several pages; he attached them to a large piece of cardboard so no turning would be necessary. Thanks to Jerry and Nickie Gaylord for their hospitality and use of the fine organ.

Several of our members went to the Lew Williams concert at the Seattle Paramount. His handling of the 4/20 Wurlitzer made the trip well worthwhile.

Many of us also crowded into the Portland Organ Grinder to hear Jonas Nordwall's Classic Nights. These programs are so popular that they required two nights, both with overflow attendance.

On November 9 we were privileged to hear Walt Stroy at the Benson High School 3/24 Kimball. This young man has earned quite a reputation as a pizza organist in Arizona and for his recordings and concerts, including his outstanding performance at the 1983 ATOS Convention in San Francisco. Vigorous promotion, with advance ticket sales, resulted in a good attendance. We had members from Bend and Eugene and several guests from Seattle who attended.

Walt's largely classical program featured

MAGIC ORCHESTRAL SOUNDS OF DAN SEMER

Detroit Theatre Organ Club — 4/34 Wurlitzer Pipe Organ
VRDS 10012 — STEREO

"Congratulations and bravo
on your record."

LUCIANO PAVAROTTI, tenor

"You created an artistic masterpiece that
permeates with ingenious imagination."

RICHARD PURVIS, organist

A Grieg Fantasia • Piano Concerto in A Minor • Anitra's Dance
Wedding Day • Peer Gynt • Tea for Two • Evergreen
Hawaii • Miami Beach Rumba • You • And More

\$10.00 postpaid — \$12.00 outside USA

VILLAGE RECORDS • P.O. BOX 633 • LA VERNE, CA 91750

Dan Semer

ORGANIST-PIANIST

"Many good wishes for your career.
God-Speed! You are a supervirtuoso that
commands musical sensitivity with nuance."

LUCIANO PAVAROTTI

The World's Favorite Tenor

M&J Enterprises

Personal Manager: Margaret Bonfiglio
P.O. Box 633, LaVerne, Calif. 91750
(714) 596-5024





Walt Strony, flanked by Terry Robson and Karen and Loren (Captain Kimball) Minear, at the console of the Kimball in Benson High School. (Roy Fritz photo)

several beautiful, but little-known works by well-known composers, a welcome variation. Also included were what sounded like a combination of "Tico Tico" and "Bumble Boogie," a flood-stage "Old Man River" and an elaborate "1812 Overture" minus artillery (no casualties). By skillful playing, Walt was able to minimize the difference between this theatre organ and a classical organ, in a Bach fugue. Thanks to Benson High and to Walt Strony for this fine program.

BUD ABEL

PIKES PEAK AREA
Colorado Springs
303/687-6530 or 303/633-4407

We have recently established a regular meeting and open console session at the Colorado Springs City Auditorium, home of the 3/8 Wurlitzer restored and installed by our chapter several years ago. Beginning in November, we will have regular gatherings, from 7:00 to 10:00 p.m., on the Sunday after the first Saturday of every month. These sessions will consist of a short business meeting (if required), a mini-concert and open console for members and guests. Some organ maintenance will also be accomplished and refreshments will be served. Visiting ATOS members are welcome to drop in.

Congratulations to Frank E. Perko III, who represented our chapter in the 1985 Young Organists Competition. We are very proud that he could participate in this new ATOS activity.

We are also in the process of setting up a 3/9 Wurlitzer in the private auditorium used as our unofficial "Chapter House." This instrument is slowly taking shape under the direction of Technical Chairman John Grunow. Members are designing and building a solid state relay to control the instrument. The chambers have been completed, thanks to the efforts of Stan Destefan and Keith Roberts. It is our hope to have this organ playing in the spring.

In other area news, the 4/58 Austin in Pueblo's Memorial Hall is now undergoing the first phase of a hoped-for total restoration. Under the leadership of a citizen's group that was formed after our members and friends stimulated an interest, about \$40,000 has been raised for this project. The complete restoration is expected to cost over \$150,000. It has been many years since the organ has been in full working condition, and we hope to have it playing to its full potential next spring.

DAVID N. WEESNER

PUGET SOUND
Seattle
206/852-2011 or 206/631-1669

A September program, hosted by the Bremerton Pipe Organ Society, featured John Nafie at the 11-rank club organ. Originally a four-rank Wurlitzer from the American Theatre in Walla Walla, Washington, Smith, Estey and Morton ranks have been added, and the organ now gets regular

use in the Bremerton Community Theatre prior to stage plays produced by the equally ambitious community actors group. Nafie, a talented, young, college-trained organist, drew a standing-room-only crowd. His love of theatre organ and his involvement in the installation and maintenance of this instrument, bring an obvious sense of pleasure to his playing. His theatre stylings are fresh, lively and musical, and his selections included well-orchestrated Gershwin tunes plus the Pachelbel "Canon in D," in addition to other favorites, all played with skill. Local tenor Tom Peters and pianist Al Kluth also joined him on the program, lending variety to the presentation.

Our concert season opened in October with Lew Williams at the Paramount, a long-anticipated event which exceeded expectations. "Fine-tuning," accomplished by the organ crew, has further improved the quality of the sound of the organ, and each artist is able to combine its resources in his own unique manner. Although Lew's relaxed and unassuming manner easily wins friends, his musicianship and flawless technique reveals a no-nonsense dedication to his craft. His transcriptions of classics, each carefully orchestrated, were well-received, including his inimitable "Rhapsody in Blue."

Inclusion of serious organ literature in a theatre organ concert sometimes brings mixed feelings from members of the audience, but a new standard of excellence is being set in the '80s by artists equally proficient in the classics and on organs being brought to their prime by dedicated technicians. Lew is no exception — his remarkable achievements indicate a future of great promise.

DIANE WHIPPLE



On September 29 we presented our Fall Pipe Organ Spectacular at the Capitol The-



1985 A.T.O.S.
"Organist Of The Year"
DENNIS JAMES

Resident Organist For
The Ohio Theatre

55 East State Street
 Columbus, Ohio 43215
 Bus. (614) 469-1045 • Hm. (614) 488-9032

- April 3 — Konzerthaus, Vienna, Austria
- April 12 — Roberson Center, Binghamton, New York
- April 26 — Civic Opera House, Chicago, Illinois
- April 28 — St. John's Pres., New Albany, Indiana
- May 11 — Rialto Theatre, Joliet, Illinois
- May 17 — Smithsonian Institute, Washington, D.C.
- AUSTRALIA / NEW ZEALAND CONCERT TOUR:**
- May 24 — Marrickville Town Hall, Sydney
- May 31 — Southward Museum, Paraparaumu
- June 8 — Capri Theatre, Adelaide
- June 15 — Civic Theatre, Ballarat
- June 21 — Karrinyup Center, Perth
- July 9 — RCCO CONVENTION — OPENING CONCERT
 Church of the Redeemer, Kingston, CANADA



John Nafie preparing a program at the Bremerton Community Theatre on the Bremerton Pipe Organ Society 11-rank organ.



Lew Williams at the Seattle Paramount console.

(Ken Gallwey photo)

atre in Davenport, Iowa, featuring Fr. James Miller of Fenton, Michigan. Fr. Miller, as we have come to expect, gave a performance sparkling with wit and humor for the approximately 1000 people in attendance.

Although he was introduced after intermission as the "Fumble-Fingered-Friar-From-Fenton" by emcee Chapter President Joan McFadden, Fr. Miller failed to live up to that billing by flawlessly performing such numbers as "Dill Pickle Rag" and "Honeysuckle Rose." The program contained a variety of styles and numbers which ably demonstrated the recent addition of a Chrysoglott and second Vox Humana to the organ. And, of course, what would one do in a theatre without a silent film? This year's was Buster Keaton's *Cops*, furnished by Blackhawk Films of Davenport. This is THE chase scene film of all time, with thousands of men in blue chasing poor Buster for blocks and blocks. I won't tell the ending, but it is worth seeing. One of the most appreciated parts of our Pipe Organ Spectaculars is the sing-along, which Fr. Miller handled effortlessly.

Once again, we were able to meet our guest artist in an informal setting at a potluck held on the Friday night preceding Sunday's

show. Everyone had a good time, ate too much, and got to know Fr. Miller personally, which is a great joy and pleasure. This was Fr. Miller's third appearance in the Quad Cities by popular request, and we are looking forward to having him return for another Pipe Organ Spectacular!

ARTHUR FELTS



RED RIVER ATOS
218/287-2671
or 701/232-6325

It was a monetary as well as artistic success, as our silent movie nights, November 1 and 2, were sellouts with waiting lines both evenings. The first half of the show featured our band, the Fargo Theatre Big Band All Stars, under the direction of James Ployhar. Their program included vocalist Harriet Olson and Lloyd Collins at the Wurlitzer. The audience joined in on one number, "Pennsylvania

6-5000," and Lloyd played the vibraphone on "Doll Dance." The 1928 comedy, *Feel My Pulse*, starring Bebe Daniels with score by Lance Johnson followed intermission. This was our twenty-second production since beginning public performances showcasing the Wurlitzer and silent films in 1974.

In December we continued our tradition of free noon hour organ concerts for two weeks before Christmas. Other organizations also use the theatre facilities, and the Sweet Adelines and F-M Ambassador Barbershop Chorus presented "Harmony for The Holidays" with Lance Johnson at the console.

At this writing, the booklet on the history of the Fargo Theatre is being printed. Watch for further details if you would like to order one.

SONIA CARLSON

**The River City
Theatre Organ Society
Omaha, Nebraska**
402/292-7799 or 402/572-1040

Bill and Maurine Durand hosted our September meeting at their home in a beautiful

Father James Miller

"Father Jim"
(313) 629-5400

401 Davis St.
Fenton, MI 48430



Tom Wibbels
Theatre Organist

impro international inc.

P.O. Box 1072 • Elkhart, IN 46515 • (219) 679-4061



Doug Kroger at the Durand's Allen digital organ.

(Tom Jeffery photo)



Brad Foster, another promising young organist in the River City Chapter.

(Tom Jeffery photo)

wooded area of Omaha. They demonstrated their three-manual Allen Digital Computer theatre organ and then gave all members a chance to play during open console. Young organist Laura Markworth opened the program with a few selections and was then joined by her sister, Kim, for a duet. Doug Kroger was the featured artist and put the organ through its paces, playing music of the season. The audience thoroughly enjoyed his excellent performance. This very pleasant afternoon was concluded with a buffet supper. After the formal program, another talented young member, Brad Foster, played for

the group.

We traveled to Lincoln for our October 5 meeting at Doug Kroger's home. Doug has a two-manual Conn theatre organ. After his mini-concert, many in attendance had a chance to play this fine instrument.

Director Bob Markworth arranged for our October 27 meeting in Trinity Lutheran Church which has a 3/30 Reuter pipe organ with drawknob console. This provided an interesting change-of-pace and an opportunity to play a church organ during open console. The featured artist was Trinity's organist, Mrs. Jean Johnson, who described the instal-

lation and resources of the Reuter, before playing a number of classical selections and hymns. After Jean's program, ATOS National President Jack Moelmann concluded the program with several hymns and a toccata by Nevin. We are indebted to Trinity Lutheran and to Mrs. Johnson for a most enjoyable afternoon.

TOM JEFFERY

ROCKY MOUNTAIN Denver, Colorado

303/797-2232 or 303/233-4716

On September 25 we hosted Kurt von Schakel on the 4/37 Wurlitzer in the Denver Organ Grinder. The restaurant was open "as usual," allowing both members and the public the opportunity to hear Kurt who was vacationing in Aspen and took a day to spend with us. Kurt's program included many popular theatre organ numbers such as the lively "Vanessa" and the delicate "If I Love Again." Kurt's style is a full theatre organ sound, minimum of percussions, maximum of technique.

On September 29, Mike Gregorich of Pueblo was guest artist at the home of Dr. Dee and Charlotte Williams on their 3/10 Wurlitzer with computer relay system. After Mike's program, which included "Body and Soul" and "Carioca," the playback system on the organ was utilized to entertain the guests with "performances" by Jonas Nordwall, Patti Simon and Donna Parker, all of whom had recorded on the computer during earlier visits. The organ was in perfect per-



Jean Johnson demonstrating Trinity Lutheran's Reuter pipe organ for the River City Chapter.

(Tom Jeffery photo)



ATLAN

INSTITUTE OF ART & TECHNOLOGY, INC.

P.O. BOX 336
WHIPPANY, NJ 07981
(201) 887-3007

N. FRANCIS CIMMINO
DIRECTOR, ADMINISTRATION

RALPH H. RINGSTAD, JR.
DIRECTOR, OPERATIONS

Popular

English Theater Organist

Jeff Barker

Concerts and
Silent Films

201 Cross Street, Apt. 8H
Fort Lee, N.J. 07024
201-461-9246 201-944-6742



forming condition, and the members were fascinated by the versatility of the computerized relay system.

In October we visited St. Francis de Sales Church to hear Frank Graboski play the organ which was originally installed in the Denver Isis Theatre. The organ had several homes between the Isis and St. Francis where several ranks have been added to this original Estey instrument. Mr. Graboski's program included "Festival Toccata" by Percy Fletcher, "The Lost Chord," and a very interesting Billy Nalle arrangement of "All The Things You Are" in a trio in a style of Bach which was beautifully done. Mr. Graboski titled his program, "Romantic Gems," and it was shared with the AGO.

PATTI SIMON

SAN DIEGO California

619/279-2867 or 619/561-2269

Summer and fall have been busy times for us with the addition of new ranks and a computer capture system to our California Theatre Wurlitzer and two social events.

A delicious potluck was held at the home of Coulter and Mildred Cunningham, followed by a wonderful mini-concert by Chris Gorsuch on the Cunningham's electronic/pipe combination, aided by Coulter on the trumpet.

Vern and Marian Bickel hosted the chapter's tenth anniversary party on October 13. Wayne and Cheryl Seppala presented the premiere performance on the Bickel's magnificent new three-manual Allen ADC 6500. The Bickels were gracious to open their beautiful



Wayne and Cheryl Seppala beside Vern and Marian Bickel's Allen ADC6500 organ.

home and new organ to over 50 of our members. Good food, fellowship and fun was enjoyed by all.

Walt Strony played the re-dedication concert on our California Theatre Wurlitzer on November 2. Our hard-working crew virtually lived at the theatre the week before the concert to re-assemble, voice, regulate and tune the Wurlitzer after its four-month shutdown. It was truly a race against time, right up until the doors opened for the concert. Mr. Strony gave a masterful performance under a tremendous strain — no practice time and the in-

evitable mechanical, tuning and ciphering problems of a "new" pipe organ. He is to be commended, not only for his superb musicianship, but also for his gracious understanding of this unfortunate situation.

WAYNE SEPPALA

SOONER STATE Tulsa

918/742-8693 or 918/437-2146

Our July meeting was held in the home of Sam and Ruth Collier with open console on

GEORGE WRIGHT

"RED HOT AND BLUE" Compact Disc

The 1st Theatre Organ Compact Disc. Plays over 59 minutes with 6 more tunes than the LP.

\$20.00 U.S. & Canada.
England \$22.00, Australia \$23.00 postpaid.

ALSO

"RED HOT AND BLUE"

George Wright and his new recording organ — a long awaited new LP record — 40 minutes — digitally recorded — exciting new arrangements — organ stoplist.

\$12.00 Postpaid in U.S.
\$14.00 Canada, \$18.00 England (U.S. Funds)

BANDA RECORDS

P.O. BOX 392 * OXNARD, CA 93032

Have You Heard?



Hector Olivera

and his 9 manual
"O-I Orchestra"

(National Tours Now Forming)

You Won't Believe Your Ears!

MPI

MUSIC PRODUCTION INTERNATIONAL

P.O. Box 86 • Newnan, Georgia 30264

Telephone: (404) 251-4704

their Gulbransen Rialto. The Colliers have recently returned to Tulsa after an absence of many years, and we're glad they're back! Sam began the evening's music by showing us what the Gulbransen could do, and we then heard music from several members.

An inspection of the Vo-Tech Robert-Morton installation was the agenda for our August meeting. A group of us met for dinner, then adjourned to the school to see the organ's progress first-hand. The evening was typically Oklahoma, hot and humid, so we didn't stay long, but it was truly wonderful to see how much had been done. Although the console is in Pryor while Hervey Barbour is installing its Z-tronics wiring, we could still turn on the blower and have wind in the two chambers. The pipes could be played manually, and we heard a good many "honks" and "peeps" during the tour! An exquisite touch was hearing Luther Eulert pick out (manually!) "Silent Night" on the Glock!

September found us back at Tulsa's Assembly of God Church for a program on the 4/14 Robert-Morton by Lorene Thomas. Actually, the organ is temporarily a 4/13 — the Tibia regulator has blown, and until it can be repaired, the organ is minus its Tibia. Lorene proved equal to the task, and her "just a few numbers" were delightful! Most enjoyable organ/piano duets were played by Lorene at the organ and Lynda Burns at the grand piano. They were terrific together and, of course, totally unrehearsed. We'd like to hear more.

In October we journeyed to Arkansas to visit two pipe organs. First stop was at Hugh and Enid Lineback's in Siloam Springs to see the progress Hugh is making on the installation of his 2/6 Kilgen with chimes. This organ originally belonged to radio station KFPW in Fort Smith, Arkansas, and was installed in the Goldman Hotel there. Bill Roberts bought it about ten years ago and moved it to Tulsa, but never put it together. Hugh bought it from Bill and moved it back to Arkansas. Hugh and Enid have added a two-story organ chamber to their delightful home, and the organ will speak through an opening in the dining room wall.

After a quick stop in Siloam Springs for lunch, we continued our journey to Bella Vista to Russell and Florence Joseph's to hear their 2/4 (pure) Wurlitzer. Russell played a varied program for us which he ended with "The Lost Chord," which he was inspired to



Mike Kinerk, program chairman, Gaylord Carter and chapter President Hal Henry at the Cal Juriet residence.

(G. W. Gerhart photo)

play after hearing Tom Hazleton at the Chicago Stadium at the recent ATOS National Convention. We heard more music from others during the afternoon, listened to Russell tell about the convention, heard organ tapes, and saw slides of a tour taken by Russell through the Wicks Organ factory. We then adjourned for dinner to the Bella Vista Country Club and left for Tulsa around eight o'clock. We were home by midnight — a long day — but fun!

DOROTHY SMITH



On October 29 Gaylord Carter played for us at the Cal Juriet residence.

On October 31 the Wurlitzer 260 Special in Gusman Cultural Center (formerly the Olympia Theatre) was heard prior to a Halloween film showing. Member Dave Thurman was at the console wrapped in a cape for the occasion. The organ at Gusman is used on an irregular basis prior to many stage and film presentations as an on-going function of our chapter.

G. W. GERHART

SOUTHWEST MICHIGAN THEATRE ORGAN CLUB

Southwest Michigan
616/343-6491 or 616/344-1438

As a member of the Arts Council of Greater Kalamazoo, we were invited to set up a display during Articipation at Crossroads Mall in Portage on September 14 and 15. This annual event allows various organizations to promote their activities such as musical, theatre or dance programs. Our display area had two electronic organs, a Hammond Elegante and a Yamaha Electone, which were played most of the time by our members. When no

Lew Williams

featured at
Organ Stop Pizza
Phoenix

for concert information write or call
5109 N. 81st Street • Scottsdale, AZ 85253
(602) 941-9020

Donna Parker

For Concert Information:

Donna Parker Productions Inc.,
P.O. Box 19371 • Indianapolis, Indiana 46219
(317) 359-9148



Darryl Calvin, Gusman Managing Director, with organist Dave Thurman at the Wurlitzer in the Gusman Cultural Center. (G. W. Gerhart photo)



John Catherwood, Betty Darling and Michael McLeieer, featured organists at the first public showing of Betty's recently installed 2/8 Robert-Morton. (Robert Suder photo)

organists were available, the Yamaha, with its modern technology, played itself. A special 45-minute performance on the Hammond was given by five of our members in the stage area on Saturday afternoon. These organists, who range in age from 15 to 82, were Neil Johnston II, Betty Darling, Evelyn Sherman, Ron Kemper and Ken Butela. Their programs included a variety of numbers and stylings. Brochures were given out telling about our chapter and ATOS.

The regular meeting on September 22 was held at the Fred Hohner home in Three Rivers. Lee Hohner played the opening program on the 3/10 Robert-Morton. This beautiful organ originally came from the Riviera Theatre in Detroit but has traveled some since then. It was shown on three home tours during conventions in Detroit when the Hohners lived in the eastern part of the state. A history of the organ and a chamber tour were provided by Lee before open console concluded the afternoon's activities.

October 20 was a special day for Betty and Harvey Darling as we met at their home in Portage for the first public showing of their recently installed 2/8 Robert-Morton. The installation was done by John Catherwood following its long trip from California. Betty was the first featured organist of the day followed by Mike McLeieer and John. John also gave us interesting information about the organ and how it came to be the instrument it is today. He spent quite a bit of time in the chamber explaining its technical aspects. Many of the 29 people present enjoyed playing during open console.

L. DIANA HASKINS

SOUTHERN CALIFORNIA TRI-COUNTIES

714/656-2777

The chapter has successfully administered a \$6750 grant for the restoration and improvement of the Wurlitzer in San Bernadino's California Theatre. With the continuing cooperation of the San Bernadino Civic Light Opera Association, owners of the theatre, the project is nearing completion with a dedication concert anticipated early in 1986.

PATRICIA A. CLARK

ORGAN-IZING POPULAR MUSIC by AL HERMANN'S

A complete course in Keyboard Harmony and arranging popular music for Organ.

AVAILABLE AT MUSIC STORES OR DIRECTLY FROM
AL HERMANN'S

1398 TEMPLE STREET

CLEARWATER, FLORIDA 33516

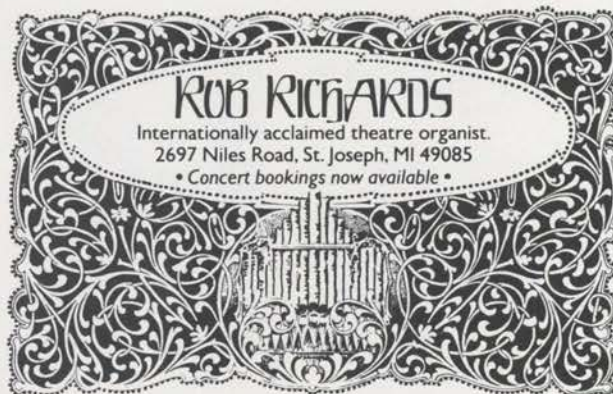



The Byrd Theatre in Richmond, Virginia. Lin Lunde on the organ and Tim Needler on the piano in the box at the left played during a showing of *The Music Man*. This venue will be featured during the 1986 ATOS National Convention. (Ray Brubacher photo)



The Mosque Auditorium, site of a private concert by Pattie Germain for the Richmond Chapter. This auditorium and its organ will be featured at the 1986 ATOS National Convention.

American Theatre Organ Society



VALLEY
OF THE
SUN
CHAPTER

Phoenix

602/972-6223 or 602/278-9107

On July 28 we traveled north to the beautiful and cool Prescott area to see and hear two lovely instruments. Walt Strony was our "traveling musician" for the day. First stop was the home of George and Linda Franklin. Theirs is a basically classical Custom Allen Computer organ, but Walt played a variety of music on it from "Swanee" to "Prelude and Fugue in D Major." We continued to the home of Dick and Evelyn Keith, where Strony entertained us on their two-manual Wurlitzer with selections from *The Student Prince*, "Slaughter on Tenth Avenue" and others. Jim Burns, a friend of the Keiths, treated us to a different kind of pipe music when he added some bagpipe tunes to the program.

On September 15 we met at the Mesa Organ Stop with Ron Rhode as featured artist. Ron's versatility was shown by numbers like "You're A Good Man, Charlie Brown," "Les Bicyclettes del Belsize" and "Li-biamo."

Lew Williams stepped in as a last minute substitute organist for our October 13 meeting at the Bill Brown residence. His program included some of the numbers he played at the

Chicago conclave and a medley of songs from *The King and I* as a tribute to Yul Brynner.

The WONDERFUL Mr. Williams was there for us again when we needed someone for our November 10 meeting. The Wurlitzer at the First Christian Church wasn't ready yet, and we needed someone who was familiar with the church's classical organ. Lew gave us a diversion from the usual theatre organ concert. He was assisted by chapter member Lila Hoffman as a very adept page-turner. We enjoyed the change of pace with music by Vierne, Widor and Dupré.

MADELINE LIVOLSI



Pattie Germain played for the club at a private concert at the Richmond Mosque on November 9. This gave all of us a chance to see and hear Pattie once again and to hear the majestic sound of the Mosque Wurlitzer. The organ has a quality all its own, mainly because of the tremendous size of the theatre. The Mosque was originally second in size only to the Los Angeles Shrine Auditorium in 1927, and even today it is one of the largest theatres in the country. The organ itself is only 17 ranks but sounds much larger. Pattie is no stranger to Richmond audiences as she has

played, for many years, the Kiwanis Travelogue Series at the Mosque.

Tim Needler, a member of our club who lives in Indianapolis, paid a surprise visit to the Byrd on August 31 and September 1. *The Music Man* was the feature, and Tim and Lin Lunde worked out a routine where Tim would play the grand piano in the box at stage left. Although it is difficult to hear the organ from the piano alcove, they did a remarkable job of staying together. Lin and Tom appeared in formal dress both nights, and the audiences loved the duo. No one can remember the organ and piano being played live together in this manner, and plans are to do it again when we can find someone brave enough to climb a ladder, crawl on hands and knees to the far corner of the box, then stand up and walk into view as if he had the entire backstage area to make an entrance. Anyway, the audience knew nothing of these problems, and that is what makes show business so exciting.

Member Bill Balz entertained us at the studio Wurlitzer in the home of member David Barnett on September 28. There was a large turnout of members and guests, and the surprise of the evening was vocalist Debra Waggoner who can belt out a song as well as any Garland or Merman. Beverly Gordon did her wonderful buffet again, and everyone had a marvelous time.

Southern Living photographed the Byrd Theatre on September 10 with a lot of emphasis on the organ. The issue will be on the newsstands in January. General Manager Duane Nelson bought some new plants for the occa-

CHRIS ELLIOTT

Organist

Now booking 1986-87 appearances

Theatre Organ and Silent Film Presentations

For concert information, contact:

CHRIS ELLIOTT

P.O. Box 11571 • Santa Ana, CA 92711

Telephone: (714) 537-4857



Now available from . . .

Don Baker
"Mr. Theatre Organ"



A.S.C.A.P.

Cassette recordings on
DETROIT SENATÉ &
BIRMINGHAM ALABAMA
Theatre Organs.
Post Paid \$9.50

Lakes at Leesburg
111 Sea Fern Court
Leesburg, Florida 32788
1-904-728-4683



Shirley and Don Jenks were hosts to the Wolverine Chapter for the September meeting. (Bill Vogel photo)



"We've done it!" L to R: Sharon Patterson, Melissa Ambrose and Judi Milliron after their program for Wolverine Chapter. (Fred Page photo)

sion and had the carpets cleaned. Several theatres on the East Coast will be featured, and the photographer stated that the Byrd was in the best condition of any.

Eddie Weaver did it again on October 13 when he played to a sold-out house at the

Byrd. The show, advertised as "An Afternoon with Eddie," coincided with the celebration of his many years as a theatre organist in Richmond. He started in Loew's Theatre in 1936 and is still going. There is no one who makes an audience feel as welcome and relaxed as Eddie Weaver, and when he had his sing-along, all 1300 voices sounded out — and loudly, too! After the intermission, Bill Zickerfoose and two members of his orchestra, The Continentals, played several tunes from the fifties. Bill was on clarinet, and his friends were on bass and drums. It was amazing how well it all turned out. From the look of the people and the whole tone of the show, it was, no doubt, the most enthusiastic organ concert ever presented in Richmond.

MILES RUDISILL, JR.

clouds, October came with a triumph of youth as a program which the ATOS Young Organist Competition second-place winner, Melissa Ambrose, and her two friends, Sharon Patterson and Judi Milliron, presented was truly delightful. The quality of their performances indicated diligent and dedicated practice. Melissa's rousing rendition of the "Radio City March" and Sharon's "Hey, Look Me Over," on the Detroit Theater Organ Club's Wurlitzer in the Senate Theatre, were but fragments of a fine program. "Chimera," an original number created by Melissa and Judi for a high school Cabaret Concert, established a claim to creative as well as performing artistry. With Sharon at the organ and Melissa at the grand piano, Judi took the spotlight with her singing of "their song." The three concluded a beautiful program with a stirring performance of "Memory" from *Cats*. They received a well-deserved ovation.

Finally, we must mention Motor City Chapter's immensely successful and warmly received concert in the Royal Oak Theatre on November 9 by the "Entertainer," Father Jim Miller, and the Dearborn Accordion Band under the directorship of Miss Lana Gore. The band is a two-time winner of the U.S. Accordion Orchestra Competition and had just returned from a three-week concert tour in Europe. Thank you, Father Jim, for your unsolicited acknowledgment of the Wolverines and your unscheduled mention of our *Cipher*, though you undoubtedly spelled it with a small "c."

CHARLES AND BETTY BAAS □



Melissa Ambrose and the Mayan Goddess of the Detroit Theater Organ Club. (Fred Page photo)



WOLVERINE CHAPTER

of the American Theatre Organ Society

Central & Lower Michigan
313/284-8882 or 313/588-7118

In September, Don and Shirley Jenks opened their home in Brighton for a Sunday gathering away from the big city. The voice of their Rodgers organ mixed with memories of how it once was. We heard the "city-within-a-city" that once teemed inside Detroit's Fox Theatre and now is silent, a tomb for memories of the past.

As if to put a silver lining back in dark

Don Baker
"Mr. Theatre Organ"

NOW BOOKING CONCERTS

111 Sea Fern Court, Lakes at Leesburg
Leesburg, Florida 32788
(904) 728-4683



A.S.C.A.P.



Rob Calcaterra

"Rob Calcaterra Workshop and Concert — Superb!!!"

Los Angeles ATOS

"One of the most popular and talented performing artists on today's theatre organ scene."

New York ATOS

"A superb evening's entertainment."

London ATOS

154 WEST 70th #9B • N.Y., NY 10023 • (212) 362-4821

CLASSIFIED ADS

Deadlines:

Oct. 10 for Nov./Dec.
Dec. 10 for Jan./Feb.
Feb. 10 for Mar./Apr.
Apr. 10 for May/June
June 10 for July/Aug.
Aug. 10 for Sept./Oct.

Send Copy To:

ATOS Advertising
1839 Weeg Way
Park Ridge, Illinois 60068

**NOTE: The first ten words
are FREE to members!**

Rates: 20¢ per word

Minimum: \$2.00

Take Advantage of this Privilege!

FOR SALE

3/12 theatre pipe organ, full set of traps and percussions, solid-state relay, blower plus rectifier included, \$18,500 U.S., or best offer. 416/864-9775.

3/12 Wicks 1926 complete, professionally dismantled from theatre, Wood Diaphone, \$19,000 or best offer. Solid-state relay would put in excellent condition (original useable). Photos and specs; send \$4 and SASE to St. Ambrose Church, 7520 S. Boulder Road, Boulder, Colorado 80303.

X66 Hammond organ solid-state transposer, mint condition. Two X66 speaker cabinets. Tenth organ from factory. Best offer. Eddie F. Buck, 413 George Street, Ridgewood, New Jersey 07450.

FOR SALE

2/3 WURLITZER THEATRE PIPE ORGAN. Toy counter, Xylophone, and Glockenspiel, with self-player action available. Ideal for smaller restaurant or pizza parlor. Contact: Muller Pipe Organ Co., 1365 South Detroit, Toledo, Ohio 43614. 419/382-6761.

Fabulous Minnesota Theatre/Delzer 4/21 Publix Wurlitzer, showroom condition, must see and hear! \$75,000. Wurlitzers: 3/8 — \$12,000; 2/5 — \$8000; 2/4 — \$4000, all original and complete; Post Horn rank \$1000; French Horn \$600, Mills Jukebox \$2000. Phone 701/223-3225, Box 1334, Bismarck, North Dakota 58502.

Rodgers 340, the ultimate in pipe sound with a plug-in. SAE for details. L. Brunetti, 624 Los Lueros Circle, Eagle, Idaho 83616. 208/939-2192.

Korg AT-12 Autochromatic Tuner. Play any note on your instrument and the AT-12 instantly indicates the note and octave (by LED) and how many cents sharp or flat (by V-U meter) in seven octaves: C1 to B7. Generates four octaves: C2 to B5 at two volumes. Calibrate tuner A = 430 Hz to 450 Hz. Quartz crystal. Case, stand, AC adaptor, batteries, earphone. One pound. One year warranty. Introductory offer: \$125 ppd. (\$180 list). Song of the Sea — Dept. ATOS, 47 West Street, Bar Harbor, Maine 04609. 207/288-5653.

Back issues THEATRE ORGAN, *Bombarde*, \$1.00 each, *Keyboard, Console, NAAM*, 50¢ each, post-paid. Minimum order \$3.00. C. Vallette, 1026 Claire, Huntingdon Valley, Pennsylvania 19006.

Kawai theatre organ — current top of the line model DX-1900. Three-manual, 25 pedals, synthesizer, percussion, auto-rhythm, and more. Like new. May deliver. List \$14,000 — Sell for \$7500 or best offer. 513/667-4207. Tipp City, Ohio 45371.

FOR SALE

MOVING SALE: Don't want to part out. Famous Buddy Cole 3/27 Wurlitzer/Morton. Full color brass and grand piano, \$45,000. 3/15 Robert-Morton, original, beautiful, \$27,500. 2/11 Robert-Morton, \$12,500. Others. Three-manual Wurlitzer, single bolster console, \$2500. Consider ALL offers, maybe motor home or? Write P.O. Box 66261, Portland, Oregon 97266.

2/10 Wurlitzer, Style H, Opus 1436 in good condition. Solo chest completely rebuilt. Some toys missing, all mechanisms intact. In storage — Pawtucket, Rhode Island. \$12,000 or best offer. 617/823-0236.

Beautiful 3/17 Wurlitzer with two added ranks. White and gold console. All solid-state system. Includes piano. Installed in restaurant. Sacrifice at \$27,000! 404/974-3744.

Bennett unit chests, chest relay, numerous offsets and 8' and 4' Diapasons. Johnson Organ Co. 701/237-0477. Box 1228, Fargo, North Dakota 58107.

UNUSUAL OPPORTUNITY

Make your hobby a prosperous business venture. For Sale — Distinctive Supper Club with three-manual theatre organ plus full percussion, grand piano, accordion and banjo. University town in upper midwest. Owner-organist retiring. Call 608/349-6622.

Rodgers 33E, three tone cabinets, metal bar Glockenspiel, setter board combination action, reverb. Reasonable offer. 313/689-4693.

Low prices on large collection of parts; Wurlitzer, Morton, pipework, chests, regulators, tremulants, percussions, relays, three-manual Morton console, 4/33 solid-state relay, miscellaneous. SASE to George Brown, 1734 Poplar, Twin Falls, Idaho 83301.

ATOS NATIONAL CONVENTION
JULY 6 TO 11, 1986



**Richmond
1986**

Capital of Southern Hospitality

THANK YOU!

Fred Beal, Lee Erwin, Tony Fenelon, Tom Gnaster, Arthur Griffin, Gary Hanson, Tom Hazleton (twice), Devon Hollingsworth, David Junchen, Lyn Larsen (twice), Mark Noller, Jonas Nordwall, Donna Parker, Perry Petta, Barbara Sellers, Phil Silberhorn, Steven Blair Smith, Don Springer, Walter Strony (twice), Bill Tandy, Don Thompson, Jeff Weiler, Dave Wickerham, and Clark Wilson (twice).

For providing our members with your
fine music during our first two years.



WINDY CITY ORGAN CLUB

P.O. Box 578121 • Chicago, Illinois • 60657

STEERING COMMITTEE — Richard Sklenar, Paul VanDerMolen, Barry Deardorff, John Novacek, Alden Stockebrand, Ione Tedei, Gib Petzke.

FOR SALE

Wurlitzer 3/17 wired for 20 ranks. Z-tronics solid-state relay, large plexiglas swell shades, completely re-leathered. Piano, English Post Horn, complete percussions and toy counter. White and gold French style console. Excellent performance organ. Price reduced for quick sale. Ned Spain, Kent #8 Oxford Heights, Albany, New York 12203. 518/869-2090.

RODGERS MARQUEE, metal bar Glockenspiel, two external speakers. \$8500. 801/278-1253.

Wurlitzer 950 electronic theatre organ. Three keyboards — 25 pedals, white and gold horseshoe design. Great sound with Tibias, kinura, lots of percussion. Excellent condition — price negotiable. W. R. Milligan, 21 S. Mallory Street, Batavia, Illinois 60510. 312/879-6610.

Choice theatre organ components for sale. CONSOLES: Wurlitzer 2m panel console, lovely woodwork, stop action pneumatics re-leathered, newly recovered keys, *choice*, \$950; Kilgen 2m console (a little gem) only \$300. PERCUSSIONS: Wurlitzer Xylophone, rare 30-note (petite scale), completely rebuilt to perfection, \$750; Wurlitzer tuned Sleigh Bells, rebuilt mint condition, \$1200. PIPEWORK: Wurlitzer 16' Bourdon offset (with chest), \$175; Wurlitzer 16' Bourdon offset (with chest), professionally mitred to fit the tiniest chamber, \$225; Wurlitzer 8' Concert Flute offset (with chest), \$175; Wurlitzer 4' Concert Flute offset (with chest), \$150; Kilgen Vox Humana (from Kilgen factory demonstration organ, one of a kind), \$200. BLOWERS: Spencer Orgbolo from Wurlitzer organs, 1 1/2 and 3 hp available, \$700 each. Rob Richards, 2697 Nile Road, St. Joseph, Michigan 49085.

2M 4RK, Wurlitzer pipe organ. Complete, contact: Bill Moore, 2000 Downing, Oklahoma City, Oklahoma 73120. 405/842-6377.

Hammond Concorde, mint condition; good theatre, jazz, classical, gospel. Drawbars, tabs, percussions, auto-rhythm, etc. \$4200 or best offer. 206/631-1669.

Conn 651 three-manual theatre organ. Two channel, 32 note AGO pedalboard, 54 speaking voices, 109 coupler and control tabs, 19 pistons. Includes two model 600 Leslie speaker cabinets with multi-rank effect on the complex voices for a full rich theatre sound. All for \$3800. 517/332-4747 after 6:00 p.m.

Wurlitzer Style 215 console for 2M 10R organ, natural mahogany, good condition; \$1000 or best offer. Blaine Ricketts — 213/428-3787.

Conn 651 plus 20 bound volumes of sheet music containing thousands of sheet music copies; \$6000, or nearest offer. 415/889-9928.

Excess inventory including Wurlitzer salicional and celeste; Robert-Morton open Diapason; Marr and Cofton open Diapason, Tibia, Tibia Minor; Dennison Tuba. All priced to sell. For list: Kevin Aikman, P.O. Box 122, Greencastle, Indiana 46135. 317/653-3876.

Rodgers Custom Theatre Organ, 36-E. Antique white finish, complete percussions, setter board combination action. Four Rodgers speakers. Lynchburg, Virginia area. Asking \$14,500. 804/846-7337.

The Greatest Organists Are Yours To Play!
 Unique & hard-to-find organ publications by the organ virtuosos & premiere arrangers.
 Jesse Crawford, Virgil Fox, Don Baker, Ethel Smith, Dave Coleman, Bill Irwin, Dave Kopp, and others!
FREE CATALOG
 Catalog Music Supply, Dept. F
 Box 641, Wayne, New Jersey 07470

FOR SALE

Kimball toy counter, \$800; Morton 30 note Xylophone, \$300; Wurlitzer Glockenspiel action plus 12, 16 foot Page Tuba boots. Laurence Crawford, 9103 Highway 101, Hamel, Minnesota 55340. 612/420-2289.

Rodgers 33-E theatre organ. Excellent condition, two Rodgers speakers, two Leslie speakers, with setterboard. Reasonable offer. 206/852-4926 or 206/631-2642.

3/15 hybrid theatre organ with piano. Pipework by Estey, Wurlitzer, Robert-Morton, all low pressure, some Haskell. Includes new brass Trumpet, Post Horn, percussions, Deegan, compact. Chests re-leathered. Console electric Reisner with remote capture. Partly crated. W. Warner — 415/459-9171.

Wurlitzer 2M console shell, with two Reisner manuals, and pedals. Could be wired to pipes or electronics. Call 415/531-9078 leave message on tape. I will return all such calls.

MISCELLANEOUS

FRANK OLSEN:

THEATRE ORGAN VIRTUOSO

A Memoir by John Sanderson. Send \$8.95 to SANMAR MARKETING, Box 567, Thorold, Ontario, Canada L2V 4W1.

Personalized study of theatre organ or piano (counter melody, harmony, technique) by cassette tape. Write or call Rosa Rio, 130 Mill Street, Huntington, Connecticut 06484, 203/929-1652. Also stereo LP 4/26 organ record, \$7.00 postpaid. *Everything's Coming Up Rosa.*

RECORDINGS

BILLY LIVE AT WICHITA POPS

Brilliant new recording puts *you* in the audience for an experience you long will remember from Billy Nalle and the great Wichita Wurlitzer. Postpaid: USA, \$11.00/Canada, \$12.50/British Isles, \$14.00/Europe, South America, \$16.00/New Zealand, Australia, \$17.00. Still available: "Show Business" (Rochester Wurlitzer) \$9.75 postpaid. Billy Nalle Music, Suite 2205, 400 West Central Avenue, Wichita, Kansas 67203. 316/264-2080.

Pipe organ albums and musicals, many Nelson Eddy. Please send SASE for list. Robert Ashby, 47230 Harry Street, Utica, Michigan 48087. 313/731-7819

If you know of recordings made by C. Sharpe Minor, contact Joan Gray, Box 442, Bobcaygeon, Ontario Canada K0M 1A0.

WANTED

Early moving picture trade magazines, pre-1930 and especially pre-1915 — *Moving Picture World*, *Billboard*, etc., single copies or runs; pre-1970 hobby publications, including *The Cipher*, *The Console*, *The Bombarde*, and *THEATRE ORGAN*; Wurlitzer, Robert-Morton, Link *et al* original sales catalogues and literature; interior and exterior photos of early (pre-1915) nickelodeon theatres. Dave Bowers, Box 1224-TO, Wolfeboro, New Hampshire 03894.

Three-manual, double bolster, horseshoe console — Wurlitzer, Page or Moller — with all electric stop action. In reasonable refinishable condition. Please write, stating price, to: Ron J. Aselton, Forest Place, Sauble Beach, Ontario N0H 1P0, Canada.

For 18 note Wurlitzer chimes — Numbers 8G, 10A, 12B, 13C, 14C#, 15D, 16D#, 17E. For Style D Trumpet pipes — Numbers 1C, 2C#, 4D#, 38C#. Gordon A. Johnson, 2931 Dara Drive, Marietta, Georgia 30066. 404/565-2424.

THEATRE ORGAN RATE CARD

AD SPACE SIZES AVAILABLE

Note New Sizes!

	Width	Height
Full Page (Bleed)	8 1/2"	11"
Full Page (Regular)	7 1/2"	9 7/8"
3/4 Horizontal (3 col.)	7 1/2"	6 1/2"
3/4 Vertical (2 col.)	4 7/8"	9 7/8"
1/2 Horizontal (3 col.)	7 1/2"	4 7/8"
1/2 Vertical (2 col.)	4 7/8"	7 3/8"
1/3 Horizontal (3 col.)	7 1/2"	3 7/8"
1/3 Horizontal (2 col.)	4 7/8"	4 7/8"
1/3 Vertical (1 col.)	2 7/8"	9 7/8"
1/4 Horizontal (3 col.)	7 1/2"	2 3/4"
1/4 Horizontal (2 col.)	4 7/8"	3 5/8"
1/4 Vertical (1 col.)	2 7/8"	7 1/4"
* 1/4 Special	3 5/8"	4 1/8"
1/6 Horizontal (2 col.)	4 7/8"	2 3/4"
1/6 Vertical (1 col.)	2 7/8"	4 7/8"
1/6 Horizontal (2 col.)	4 7/8"	1 7/8"
1/6 Vertical (1 col.)	2 7/8"	3 3/4"
Professional Card	3 3/8"	2"

* 1/4 Special size limited to Professional Card pages.

Camera-ready copy is requested as the publication is printed offset. Typesetting, photo reproduction, layout, proofing, cropping, reversing, bleed layout and any other mechanical costs requested by the advertiser or agency will be charged by the publisher at nominal rates.

ADVERTISING RATES

Black & White, one time

Front Cover — not sold	
Fourth Cover	\$280.00
Inside front cover	250.00
Inside back cover	250.00
Page	225.00
3/4 Page	155.00
1/2 Page (Horiz. or Vert.)	140.00
1/3 Page (Horiz. or Vert.)	100.00
1/4 Page (Horiz., Vert. or Special)	85.00
1/6 Page (Horiz. or Vert.)	75.00
1/6 Page (Horiz. or Vert.)	68.00
Column inch	25.00

Bleed: Bleed accepted for full page advertisement only.

Special positions available at 15% above space rates.

FOUR-COLOR

Full Page 660.00

PROFESSIONAL CARDS

3 3/8" Wide x 2" High

6 Issue Contract \$75.00

2 Issue Trial 35.00

(Payment must accompany order.)

CLASSIFIED:

20 cents per word per insertion.

Minimum \$2.00

MECHANICAL REQUIREMENTS:

Trim Size 8 1/2" x 11"

Gutter Margins 1/2"

Top & Bottom Margins 9/16"

Outside Margins 1/2"

Bleed: Add 1/8" to top, bottom and outside margins for trim. Keep reading material at least 1/4" inside the trim.

Page: 7 1/2" x 9 7/8"

Bleed: 8 1/2" x 11"

(without allowance for trim)



Think Big:

ADC-6500

Sooner or later, nearly everyone wants an Allen. So, why work your way through brands and models? Start at the top!

Just look at it — immense tonal resources waiting for you. Traditional theatrical voices and percussions delivered in *digital realism*. And beyond what you can see, you get the Alterable Voice with card reader bringing you hundreds of stops in addition to those included with the organ.

Tonal variety of the ADC-6500 will musically absorb you for a lifetime. Start now — at the top. And think big!

See our business reply card in the binding of this magazine for literature and recording offer.

Allen organs

MACUNGIE PA 18062
COPYRIGHT © 1985